



<b>Safety Notices</b> .....	<b>1</b>
Disclaimer .....	1
Liability .....	2
<b>Introduction</b> .....	<b>3</b>
Accessories .....	3
Unit Overview .....	3
Features .....	4
Specifications .....	4
Declaration of Conformity .....	4
External Communication Connections .....	5
Printer .....	6
<b>Unpacking the Instrument</b> .....	<b>7</b>
Unlock Shipping Brackets .....	7
Instrument Placement .....	10
Leveling Instrument .....	10
<b>Installation</b> .....	<b>11</b>
Connecting AC Power .....	11
Grain Drawer .....	12
Optional Bottomless Grain Drawer .....	12
<b>Navigation</b> .....	<b>13</b>
Using External Devices .....	13
Touch Screen Button Functions .....	13
Home .....	13
Power Off .....	14
Initiate .....	14
Print .....	14
Back .....	14
Abort .....	14
Enter .....	14
USB .....	14
User .....	14
Instrument Information .....	15
LCD Display Touch Screen Calibration .....	15
Keypad .....	15
Clean .....	15
<b>Password Restrictions</b> .....	<b>17</b>
<b>Setup</b> .....	<b>19</b>
Product .....	19
Edit Existing Product .....	19
Edit Product .....	21
Create Product .....	22
Delete Product .....	23
Load New Product .....	24
Administrative Settings .....	26
To Change a Known User Name/Password .....	26
System Setup .....	27
Printer Setup .....	27
Adding a Header and Footer to Ticket .....	29
Streaming Data Serially .....	29



<b>Setup continued</b> .....	<b>30</b>
Printer/Scale Setup .....	30
Language and Keyboard Settings .....	31
Sample Setup .....	33
Result Setup .....	35
Export Data Format .....	37
Time .....	38
Units .....	39
Owner Data .....	40
Service Data .....	41
LCD Display Touch Screen Calibration .....	42
Data Storage Capacity .....	43
Check Scale .....	44
Network Setup .....	47
Update Instrument .....	47
<b>Startup</b> .....	<b>49</b>
Power Down .....	50
<b>Analyzing Grain</b> .....	<b>51</b>
User Login (Optional) .....	51
Selecting Product .....	53
Performing a Grain Analysis .....	53
Hopper Level Indicator .....	54
General Cleaning Tip .....	57
Database Memory Messages .....	58
Database Memory Full Warning .....	58
Out of Memory .....	59
Data Drive Memory Low .....	59
Data Drive Out of Memory .....	60
<b>Results</b> .....	<b>61</b>
Refine Query Options .....	62
Maximum Records to Return .....	62
Maximum Records to Print .....	62
All Products .....	63
Product .....	63
User .....	63
Sample ID .....	63
Last .....	63
Unable to Show Query Results .....	63
Audit Trail .....	64
View Products .....	66
<b>Grain Calibrations</b> .....	<b>67</b>
<b>Diagnostics</b> .....	<b>69</b>
<b>Maintenance</b> .....	<b>71</b>
External Cleaning .....	71
Internal Cleaning .....	71
Daily Clean Method .....	72
Extensive Cleaning Method .....	74
Cleaning the Temperature Sensor Probe .....	77



<b>Troubleshooting</b> .....	<b>81</b>
Error Messages .....	82

<b>Warranty</b> .....	<b>85</b>
-----------------------	-----------





## SAFETY NOTICES

Safety notices are one of the primary ways to call attention to potential hazards. An absence of specific alerts does not mean that there are no safety risks involved.



**This Safety Alert Symbol identifies important safety messages in this manual. When you see this symbol, carefully read the message that follows. Be alert to the possibility of personal injury or death.**

---

### **⚠ WARNING**

Use of the word **WARNING** indicates a potentially hazardous situation which, if not avoided, could result in death or serious injury.

---

### **⚠ CAUTION**

Use of the word **CAUTION** with the Safety Alert Symbol indicates a potentially hazardous situation which, if not avoided, may result in minor or moderate injury.

---

### **CAUTION**

Use of the word **CAUTION** without the safety alert symbol indicates a potentially hazardous situation which, if not avoided, may result in equipment damage.

---

## DISCLAIMER

DICKEY-john reserves the right to make engineering refinements or procedural changes that may not be reflected in this manual. Material included in this manual is for informational purposes and is subject to change without notice.



## LIABILITY

DICKEY-john designed the GAC<sup>®</sup> 2500 to measure oilseed and grain moisture content. We rigorously test and calibrate each instrument before it leaves the factory. Use of the instrument in the field, however, is subject to environmental and operating conditions beyond our control. As a result, we are unable to take responsibility for those conditions and any damages that might follow incorrect results due to those environmental or operational conditions.

Therefore, we expect the operator to take responsibility to assure that the results of the testing is as accurate as possible by following approved maintenance procedures on a regular basis, by cleaning the instrument and its sensors on a regular and as-needed basis depending on the amount of dust, dirt, and debris encountered in the instrument's use, by monitoring performance using daily check samples, and by adhering to the check procedures set forth in the manual. As with any kind of sophisticated equipment, optimal results depend in part on proper cleaning and maintenance.

For questions concerning these issues, refer to the product warranty, or call your DICKEY-john representative.



## INTRODUCTION

The DICKEY-john Grain Analysis Computer GAC<sup>®</sup> 2500 (models UGMA and INTL) quickly tests grain and automatically calculates moisture content, temperature, and test weight (bulk density) of the sample. The unit prompts for sample loading, tests the sample, and displays the results.

*NOTE: This manual addresses setup and operation of the DICKEY-john Grain Analysis Computer GAC<sup>®</sup> 2500 instrument models UGMA and INTL.*

## ACCESSORIES

The following list of components are included with the unit and can be ordered as replacement parts:

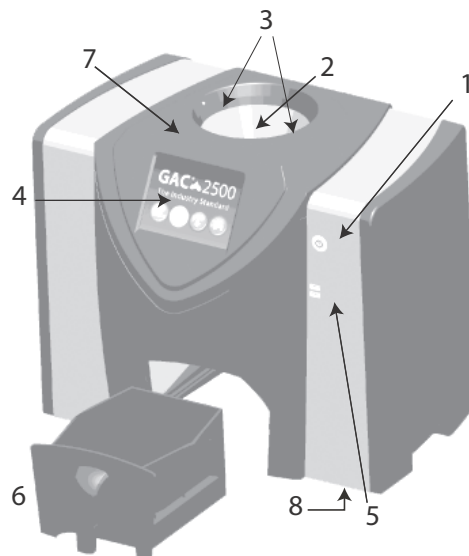
- 110V power cord p/n 203150002 (model GAC 2500-UGMA)
- 220V power cord p/n 203150005 (model GAC 2500-INTL)
- Operator's manual p/n 11001-1505E
- Cleaning brush p/n 206410003
- Grain drawer p/n 468071541
- Grain drawer bottomless (optional) p/n 468071542

## UNIT OVERVIEW

1. Power (on/off) button
2. Hopper
3. Hopper full sensors
4. Touch screen display
5. USB connections (2) front (2) back
6. Sample drawer
7. Bubble level
8. Adjustment feet (4)

*Figure 1*

*GAC2500 Overview (Front of Unit)*





## FEATURES

- Color touch screen display guides users through testing and setup
- Easy-to-use user interface
- Fast, accurate grain analysis
- One core calibration for all grains
- Alpha/numeric sample identification with the ability to add an optional extended keyboard or bar code reader via USB
- Error messages display when out-of-limits moisture, grain weight, or grain temperature occur
- Customizable work environment
- Optional password protection
- Storage of 3,000 grain tests
- Large storage to handle complete grain calibration library
- Internal memory capacity to handle future upgrades
- Printing capabilities
- A variety of external communication options

## SPECIFICATIONS

- Operating temperature: 36 to 113 degrees F (2 to 45 degrees C)
- Power: 110/220V, 50/60 Hz, 30/35 VA
- Humidity: 20 to 90% noncondensing
- Grain temperature: -4 degrees F to +113 degrees F (-20 degrees to +45 degrees C) depending on grain calibrations
- Storage/transit temperature: -4 to +140 degrees F (-20 to +60 degrees C)
- Moisture range: 5 to 45% (grain dependent)
- Approximate Weight: 25 lbs.
- Approximate dimensions: 17"H x 19"W x 14"D
- A USB memory devices less than or equal to 2GB in size formatted as FAT is recommended for extracting data from instrument

## DECLARATION OF CONFORMITY

The GAC<sup>®</sup> 2500 is in conformity with the provisions of the following directives and regulations:

- EN2006/95/EC Low Voltage Directive
- EN2004/108/EC EMC Directive
- EN61010-1 Safety requirements for electrical equipment for measurement, control, and laboratory use operating at a maximum altitude of 6562 feet (2000 meters)
- CAN/CSA - C22.2 NO. 61010-1 and ISA - 82.02.01 (IEC 61010-1 MOD) and UL61010-1
- NTEP GRAIN ANALYZE (NCWM publication 14 and NIST Handbook 44) (model GAC 2500-UGMA)



## EMC

EMC conformity to EN 61326-1:2006 (Electrical Equipment for Measurement, Control, and Laboratory use) as follows:

### Immunity

- Radiated RF field EN 61000-4-3 (2002)
- Conducted RF voltage EN 61000-4-6 (1996) + A1 (2001)
- Fast transient/burst EN 61000-4-4 (2004)
- Electrostatic discharge (ESD) EN 61000-4-2 (1995) + A1 (1998) + A2 (2001)
- Surge EN 61000-4-5 (1995) + A1 (2001)
- Voltage dips and interruptions EN 61000-4-11 (2004)

### Emission

- Radiated emission CISPR II:2003 + A1: 2004
- Conducted emission CISPR II:2003 + A1: 2004

## EXTERNAL COMMUNICATION CONNECTIONS

*NOTE: A USB memory devices less than or equal to 2GB in size formatted as FAT is recommended for extracting data from instrument*

- 4 USB connections (2 in front, 2 in back) to connect a keyboard, mouse, printer or flash drive. Up to 3 devices can be active on USB.
- 1 USB connection to connect the GAC<sup>®</sup> 2500 to a PC for downloading of software to the device, installing calibrations, or remotely accessing data from the instrument.
- 1 ethernet connection to connect the GAC<sup>®</sup> 2500 to a PC or network for downloading of software to the device, installing calibrations, or remotely accessing data from the instrument.
- 1 RS232 serial port printer connection

*Figure 2*

*External Communication Connections (Back of Unit)*



## CAUTION

**Appropriate space must be left around the input power connector to allow easy disconnection at the unit.**



## PRINTER

An optional printer that is RS232 compatible or a USB printer that supports Printer Control Language (PCL) can connect to the GAC<sup>®</sup> 2500 to print test data results to a ticket. The ticket can be setup to include the facility name and address, product, date and time, sample ID, customer ID, grain calibration date, percent moisture, grain temperature, test weight, and errors. The data can be automatically printed at the end of each measurement cycle or manually initiated by pressing the **Printer** button.

*Figure 3*

*Printer*

---





## UNPACKING THE INSTRUMENT

### UNLOCK SHIPPING BRACKETS

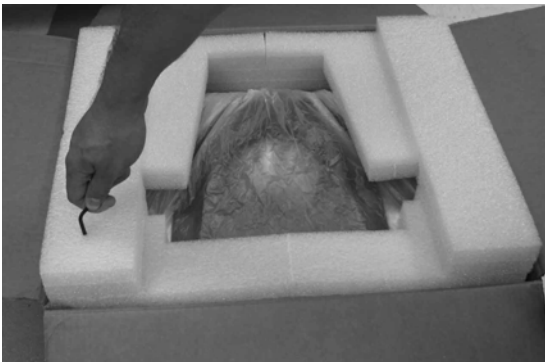
The GAC® 2500 instrument contains (2) shipping brackets that secure the measurement cell during shipping. After unpacking the instrument, the shipping brackets must be unlocked and placed in the operating location before proceeding to setup and operation.

#### To unlock shipping bracket:

1. Remove Allen wrench from upper foam packaging insert.

*Figure 4*

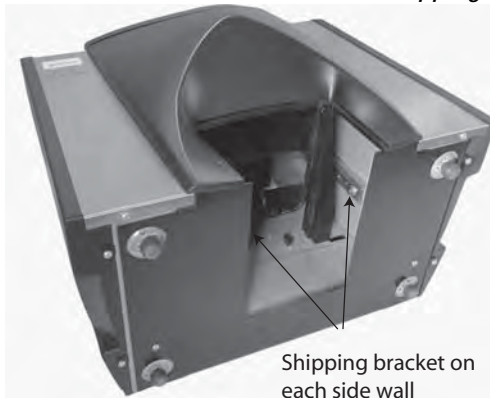
*Remove Allen Wrench*



2. Carefully remove unit from packaging and place on a flat, sturdy surface.
3. Remove grain drawer and set aside.
4. Place unit on its backside. Shipping brackets are located on the left and right side wall.

*Figure 5*

*Remove Grain Drawer and Locate Shipping Brackets*



5. Loosen hex bolt from the shipping locked location.



*Figure 6*

*Loosen Hex Bolt from Bracket*



6. Remove hex bolt and set aside.

*Figure 7*

*Remove Hex Bolt*



7. Press down on the bracket to release.

*Figure 8*

*Press Down on Bracket*

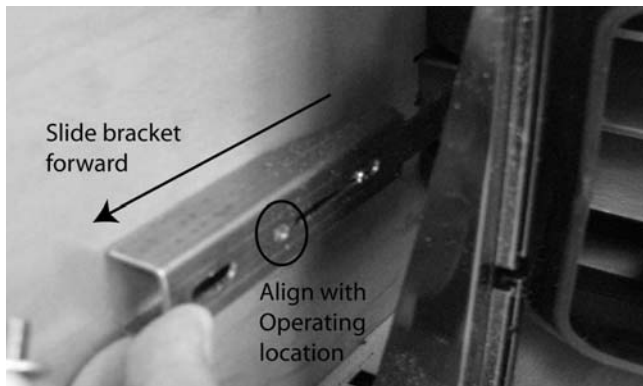




8. Slide bracket forward and align with operating location.

*Figure 9*

*Slide Bracket Forward*



9. Insert hex bolt into operating location hole and securely tighten using the Allen wrench.

*Figure 10*

*Insert Hex Bolt and Tighten*



10. Perform the same procedure to the other bracket.
11. Once both brackets are securely tightened to the operating location, place unit upright.

**IMPORTANT: If for any reason this unit is shipped or transported, the hex bolts should be removed from the operating location and secured back to the shipped locked location to protect the measurement cell during transit!**



## INSTRUMENT PLACEMENT

Place the instrument in a clean environment that is protected from rapid changes in ambient temperature and vibration. Avoid a hazardous (classified) location as defined in Article 500 of the NFPA Handbook of the National Electrical Code.

- Instrument should be placed on a flat, level surface that does NOT exceed more than 1 degree of tilt (left to right and front to back).

**CAUTION: A surface that exceeds this requirement can effect measurement results.**

- Surface should be vibration free.

**CAUTION: Vibration from other machines or devices can effect measurement results.**

## LEVELING INSTRUMENT

A bubble level located on the top surface of the instrument aids in leveling the instrument for optimum test weight measurement.

- Adjust the feet (4) on instrument bottom until bubble is in the center of the level.



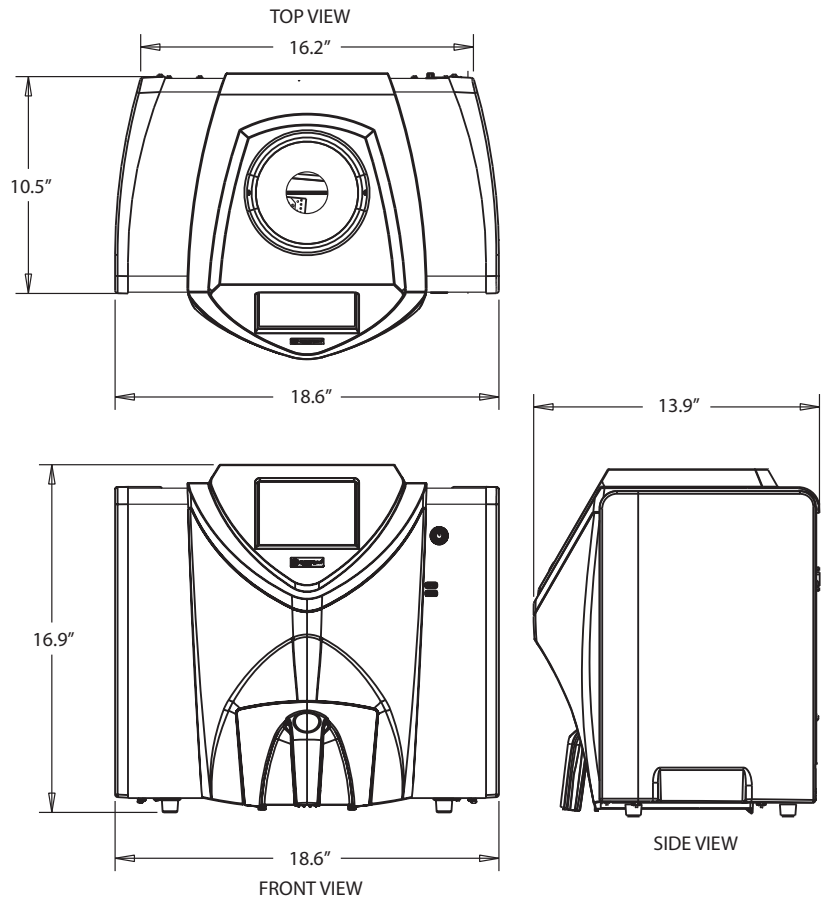
## INSTALLATION

The GAC<sup>®</sup> 2500 unit requires minimal setup. The unit is fully assembled and ready for operation after attaching the AC power cord and inserting the grain drawer.

**NOTE:** After unpacking, visually inspect for damage occurring during transit. Save all packing materials until inspection is complete. If damage is found, file a claim with the carrier immediately and notify your DICKEY-john sales representative.

**Figure 11**

### Unit Dimensions



## CONNECTING AC POWER

1. Securely connect power cord into the AC plug connection (Figure 2) located on the back of the unit.
2. Plug the male end into an appropriate 3-wire (grounded) outlet.

### **CAUTION**

The grounding pin on the line cord connects directly to the GAC<sup>®</sup> 2500 frame. When using an adapter ensure the grounding wire is connected properly to a good earth ground to prevent a shock hazard.



## GRAIN DRAWER

The unit is equipped with a standard grain drawer with handle. An optional bottomless grain drawer is available for purchase from DICKEY-john.

## OPTIONAL BOTTOMLESS GRAIN DRAWER

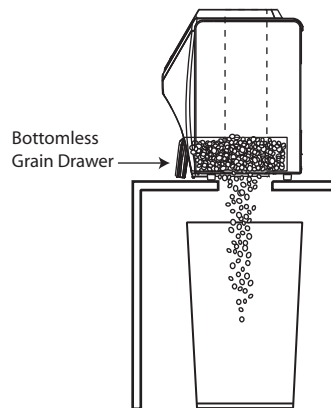
Part Number: DRAWEROPGAC2500

A bottomless grain drawer is used with a flow-through work counter that allows the tested grain samples to fall through to a larger container below. The size of the hole must be at least equal to the drawer dimension and located directly beneath the grain sample drawer.

*NOTE: Contact DICKEY-john Technical Support at 1-800-637-3302 for additional information on grain drawers.*

*Figure 12*  
*Flow Through Work Counter*

---





## NAVIGATION

The user interacts with the GAC<sup>®</sup> 2500 via the LCD touch screen display. Screen interaction by finger touch or using a dull, pointed object, such as a stylus or pen is recommended.

Refer to Maintenance section for cleaning display.

### CAUTION

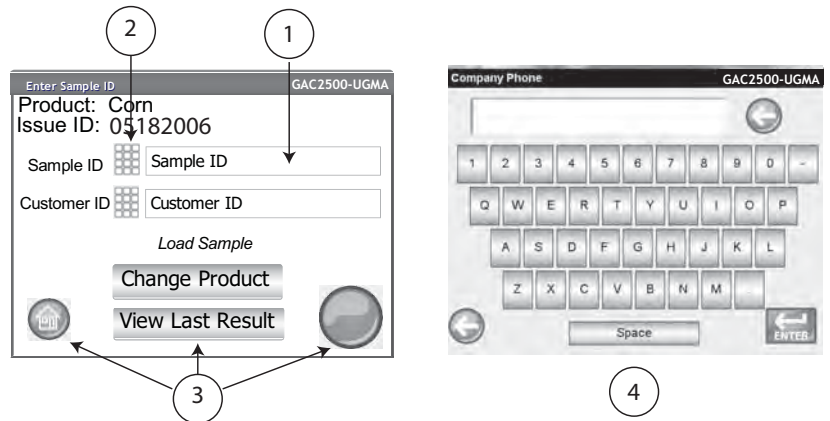
**Do not use any sharp objects on the display. Damage to screen can result.**

The following methods allow navigation through and interface with the unit:

1. Text input boxes
2. Keypad icon (enables keyboard)
3. Buttons
4. Keyboard

*Figure 13*

*LCD Touch Screen Display*



## USING EXTERNAL DEVICES

The following external devices can be used to enter data and navigate through the screens by connecting to the USB ports (2 front/2 back):

- keyboard
- mouse
- barcode scanner

## TOUCH SCREEN BUTTON FUNCTIONS

### HOME

**Home** button is available on most screens and, when pressed, returns to the Main Menu screen.





## POWER OFF

**Power Off** button turns the system off from the touch screen display. The system must be turned on using the On/Off button located on the front panel but can be turned off from either the screen display or the On/Off button.



## INITIATE

The **Initiate** button is used to analyze grain and has 3 states of operation:

Green = proceed to begin test

Yellow = an action is required to proceed

Red = system cannot process; error has occurred



## PRINT

**Print** button allows printing test results to a local printer. Refer to the Setup section for print requirements.



## BACK

**Back** button returns to the previous screen.



## ABORT

**Abort** button dumps grain from hopper, empties the cell, and aborts test.



## ENTER

**Enter** button accepts action taken and proceeds to next screen.



## USB

**USB** button is used when connecting the unit direct to a computer for downloading software and installing calibrations.



## USER

**User** button appears on the Main Menu screen only if a User ID has been enabled in System Setup. Requires a tester to enter a User Name before a grain analysis can proceed and will print on a ticket.



## INSTRUMENT INFORMATION

**Instrument Information** button appears on the Main Menu screen providing details regarding unit service date, serial number, and software version. Typically used for troubleshooting purposes.



## LCD DISPLAY TOUCH SCREEN CALIBRATION

**Display Touch Screen Calibration** button re-calibrates the display when screen responsiveness does not occur effectively to a finger touch or stylus.



## KEYPAD

The **Keypad** icon appears on those screens that require text entry. Pressing the Keypad icon opens the virtual keyboard for typing text in English on the screen. The virtual keyboard is used when an external keyboard, mouse, or barcode scanner are not available.

*Figure 14*

*Keyboard*



## CLEAN

**Clean** button appears on the Instrument Information screen and allows cleaning the cell and door using an automated process. During the cleaning sequence, the hopper door automatically opens.





## PASSWORD RESTRICTIONS

Setting an Admin user name and password to restrict system settings to be controlled by an administrator are optional. The unit is shipped with an Admin user name and password setting of "GUEST".

Keeping the Admin user name and password as "GUEST" retains the unit in open access mode allowing any user to enter System Settings and modify unit settings.

**IMPORTANT: To restrict access to System Setup that affects overall unit functionality, a new Admin user name and password must be created.**

### To Create an Admin User Name and Password:

1. At the Main Menu screen, press the **Setup** button.
2. Leave the Admin Username and Password as GUEST and press the **Enter** button.
3. At the Setup screen, press the **Admin Settings** button.
4. At the Enter New Password screen, press the Admin Username keypad icon and enter an administrator user name.
5. Press the **Enter** button to accept.
6. Enter a Password and re-enter password to confirm.
7. Press the **Enter** button to accept.

*NOTE: An external keyboard, barcode scanner, or mouse can be used to enter data into the unit.*

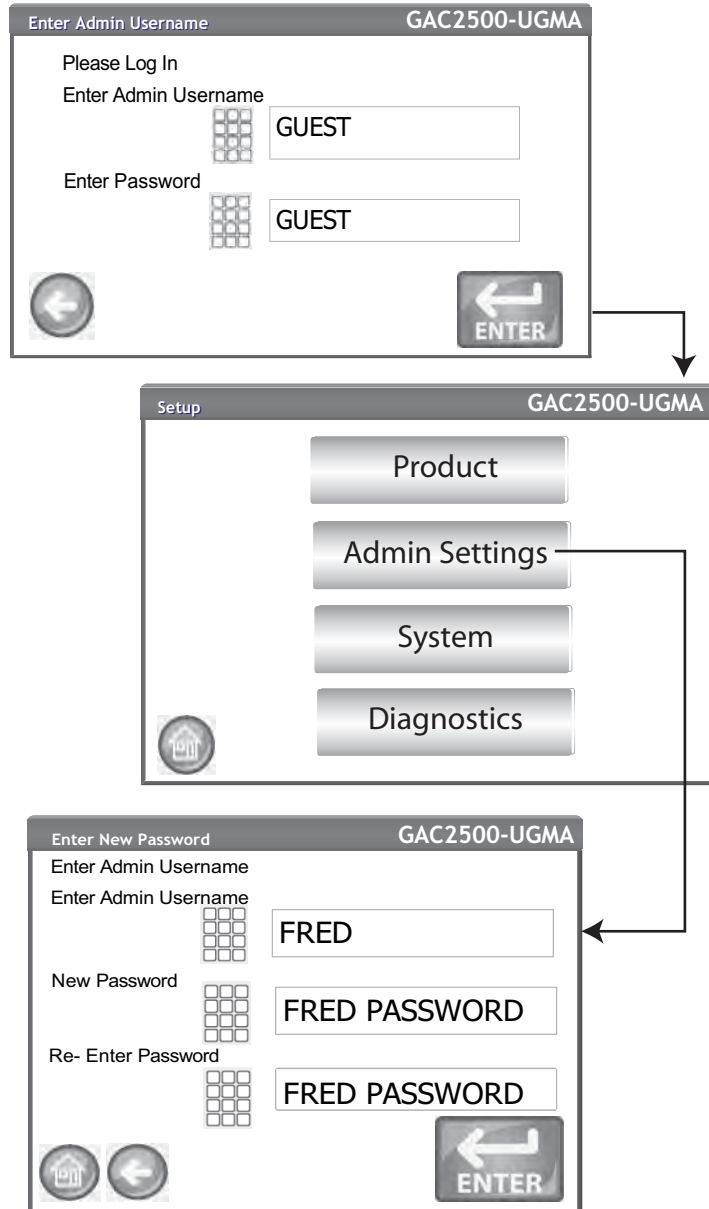
Once a new password is created, the unit is configured so that an administrator name and password is required to gain entry into the System Setup screens. Password and User Name can be any combination of letters and numbers.

Refer to Administrative Settings in the System Settings section to change an Administrator user name and password or reset to open access.

**IMPORTANT: The following words should be not used as User Names: (ROOT, GUEST, REBOOT, RESET).**



Figure 15  
Password Screen





## SETUP

Setup establishes basic unit operating parameters and allows customization of the user interface by:

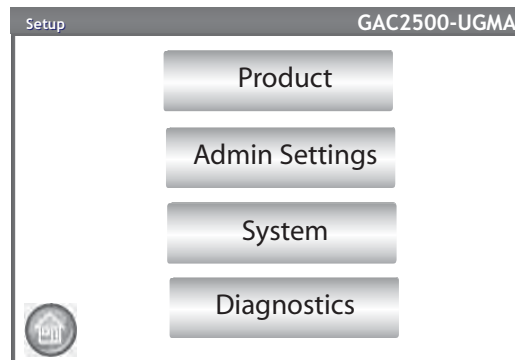
- Editing an existing product and loading new products (Product button)
- Setting administrative levels (Admin Settings button)
- Setting system parameters for external devices, language/locale preferences, time/date, sample result output, unit measurement, sample/customer ID's, delete records, and printing formats (System button)
- Diagnostics for troubleshooting and unit information (Diagnostic button)

### To View Setup Options:

1. At the Main Menu screen, press the **Setup** button.
2. Enter User Name and Password, if required, and press the **Enter** button to display the Setup screen. If defaulted to Name (Guest) and Password (Guest) press the **Enter** button.

*Figure 16*

*Setup Screen*



## PRODUCT

The Product screen is used to:

- Edit existing products
- Load new products

### EDIT EXISTING PRODUCT

If for any reason non-NTEP calibrations need to be adjusted, certain product parameters can be changed as follows:

- Modifying moisture and test weight bias and moisture and test weight slopes
- Creating a new product by copying a similar product (duplicated and saved using a different name and Issue ID)
- Deleting an existing product from appearing on active screens

*NOTE: NTEP calibrations are regulated and cannot be altered.*

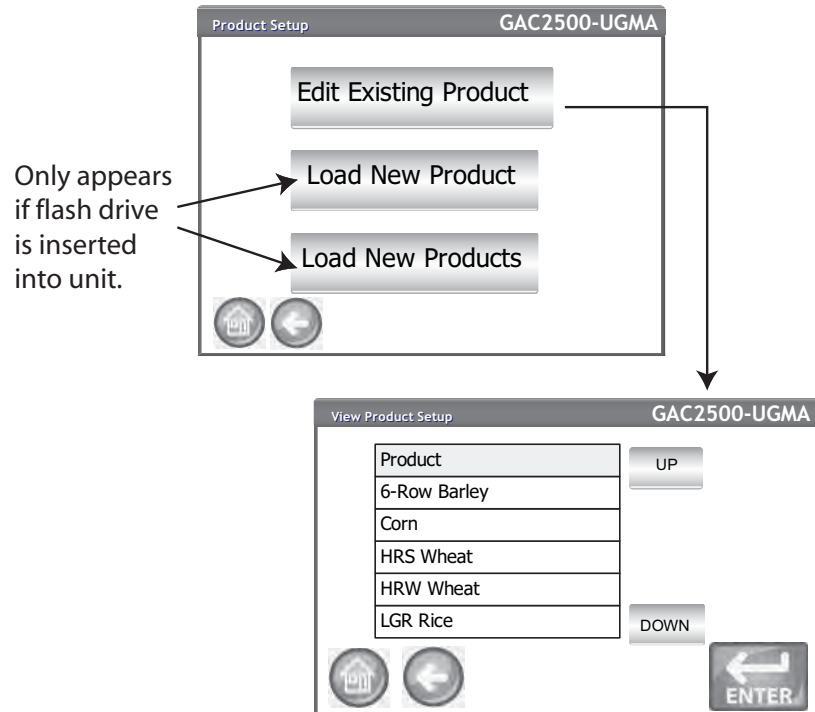


## To Edit an Existing Product:

1. At the Product Setup screen, press the **Edit Existing Product** button.
2. At the View Product Setup screen an alphabetical product list appears. Press the **Up** or **Down** button to display additional products.

Figure 17

Edit Existing Product Screens



3. Press the desired product to highlight and press the **Enter** button to select. Once the product is selected, the product's parameters display in a table.
4. Select the desired action:
  - Edit product (does not display on screen for NTEP calibrations)
  - Create product
  - Delete product



## EDIT PRODUCT

A product's moisture bias, test weight bias, moisture slope, and test weight slope can be changed at this screen. All NTEP calibrations are locked and cannot be modified. A product's calibrations should only be changed by an authorized user.

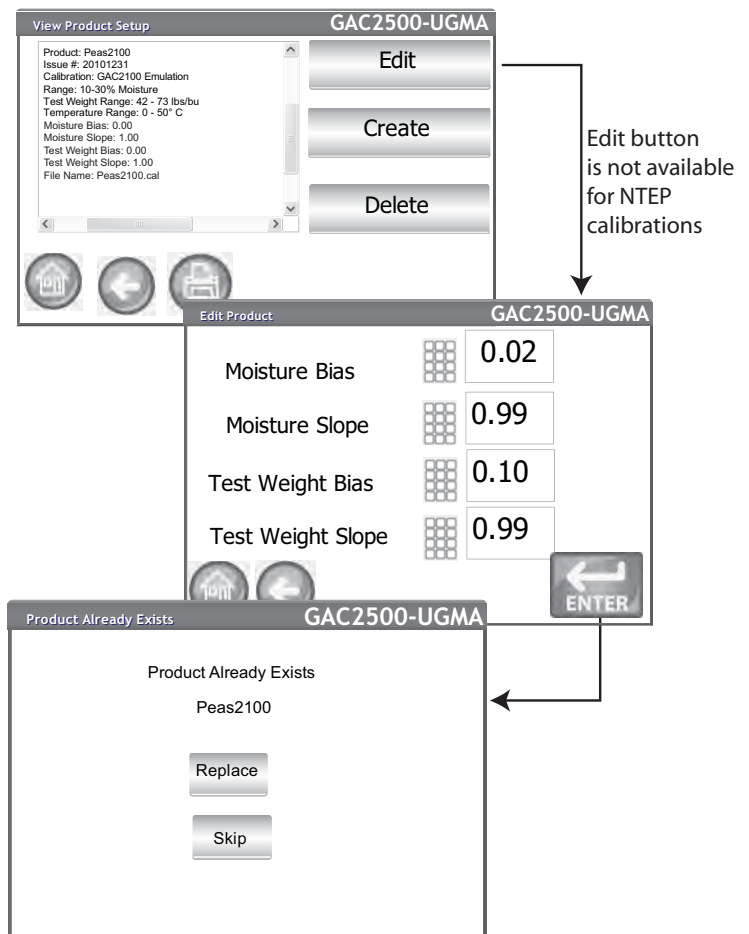
**NOTE:** A product's detail at the View Product Setup screen can be printed by pressing the **Print** button.

### To Edit a Product:

1. At the View Product Setup screen, press the **Edit** button.
2. At the Edit Product screen, press the keypad icon to modify a product's parameters.
3. When finished, press the **Enter** button.
4. Confirm product replacement by pressing the **Replace** button at the Product Already Exists screen. The **Skip** button returns to the previous product's bias and slope setting.
5. The new bias and slope appears in the product table on the View Product Setup screen. The product name and Issue ID will remain the same.

**NOTE:** An external keyboard, barcode scanner, or mouse can be used to enter data into the unit.

**Figure 18**  
**Edit Product**





## CREATE PRODUCT

A new product can be created by copying a similar product's parameters. Creating a new product name and Issue ID prevents an existing product's parameters from being overwritten.

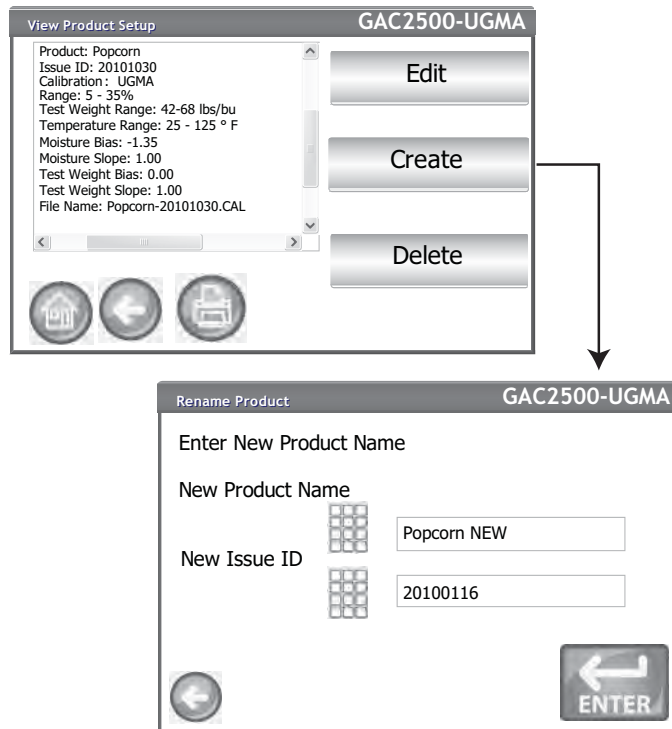
*NOTE: An external keyboard, barcode scanner, or mouse can be used to enter data into the unit.*

### To Create a Product:

1. At the View Product Setup screen, press the **Create** button.
2. At the Rename Product screen, the product name and NEW appears as the default name.
3. Press the keypad icon to enter a different product name, if desired.
4. A new Issue ID is automatically defined for the new product. Press the keypad icon to enter a different Issue ID, if desired.
5. Press the **Enter** button to save.

Figure 19

Creating a Product Screen





## DELETE PRODUCT

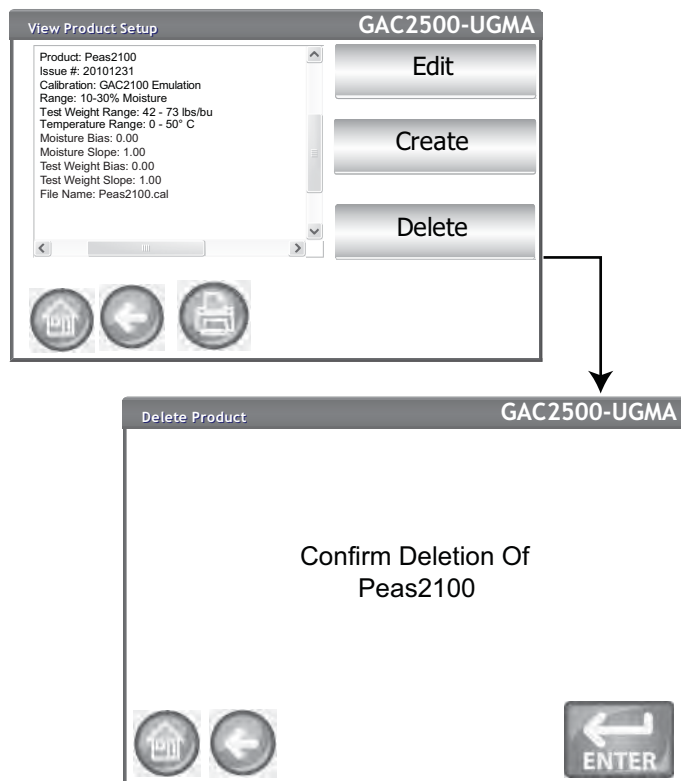
A product and its calibrations can be deleted so that it does not appear on the active user screens. A product and its history is stored in the unit's database and can still be viewed on the Audit Trail screen after it has been deleted.

### Deleting a Product:

1. At the View Product Setup screen, press the **Delete** button.
2. At the Delete Product screen, press the **Enter** button to confirm deletion.

Figure 20

Delete Product Screen





## LOAD NEW PRODUCT

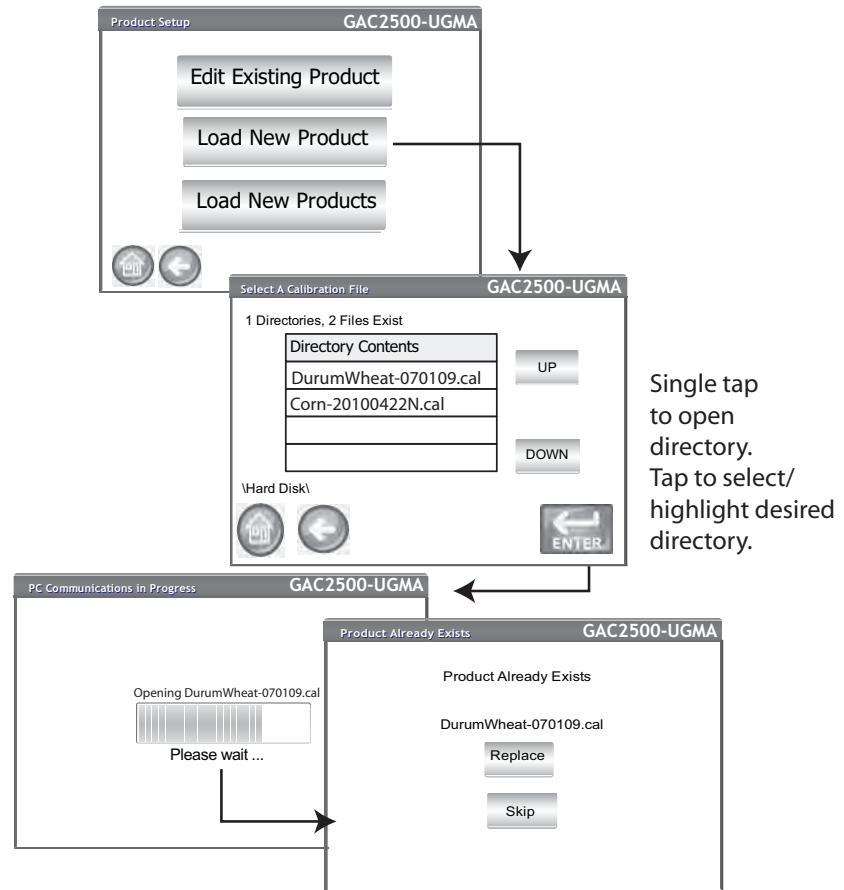
New product calibrations can be loaded to the GAC<sup>®</sup> 2500 using via a USB memory device. The **Load New Product** buttons only appear when a USB memory device is inserted in the unit.

### Loading a Single Product:

1. Insert the USB memory device to the unit's USB port on front panel of unit.
2. At the Product Setup screen, press the **Load New Product** button.
3. Navigate to the directory where the product is located, press on the product name to highlight, and press **Enter** to begin download. A progress bar indicates downloading status.
  - A single tap is required to select the desired file.
  - Pressing “..” located at the top of the list returns to previous level in the directory structure.
4. If a product calibration already exists on the instrument, accept the new calibration by pressing the **Replace** button or the **Skip** button to revert to the existing product.

**NOTE:** Contact DICKEY-john Technical Support at 1-800-637-3302 for assistance with obtaining updated calibrations or with transferring data to the unit.

*Figure 21*  
*Load New Product Screen*





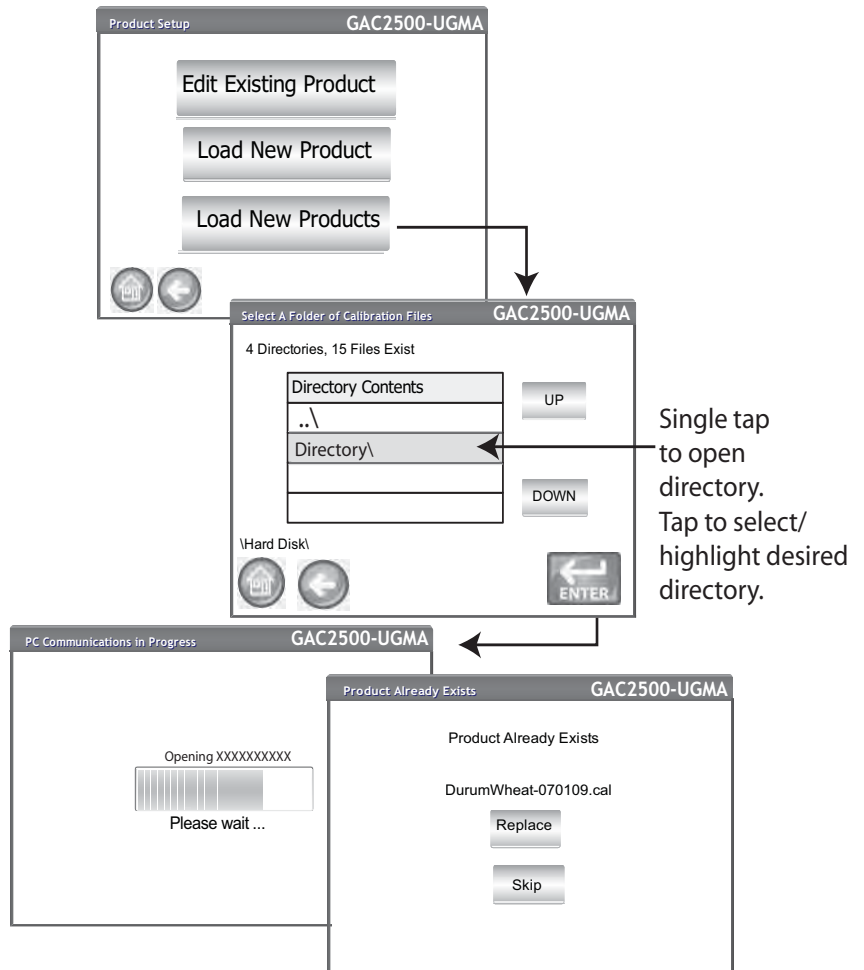
*NOTE: Product calibrations are available for download at DICKEY-john's website. [www.dickey-john.com/products/Agriculture/Moisture Testing/GAC2500/Get Support/Downloads](http://www.dickey-john.com/products/Agriculture/Moisture%20Testing/GAC2500/Get%20Support/Downloads).*

*NOTE: You must know the directory where the files are saved as names do not display.*

## Loading Multiple Products:

1. Insert the USB memory device to the unit's USB port on front panel of unit.
2. At the Product Setup screen, press the **Load New Products** button to load all products from the selected directory of the memory device or PC.
3. When loading multiple products, navigate through the directory structure and highlight the directory containing the desired products to load. A progress bar indicates downloading status.
  - A single tap selects the desired directory.
  - Pressing “..” located at the top of the list returns to the previous level in the directory structure.
4. Press the **Enter** button to begin download.
5. If product calibrations already exist on the instrument, accept new calibrations by pressing the **Replace** button or the **Skip** button to revert to the existing product.

**Figure 22**  
*Load Multiple Products Screens*





## ADMINISTRATIVE SETTINGS

If the instrument is set with an administrator password, the password can be changed to a different admin user name and/or password.

*NOTE: Refer to the Setting Password Restrictions section for creating a user name and password.*

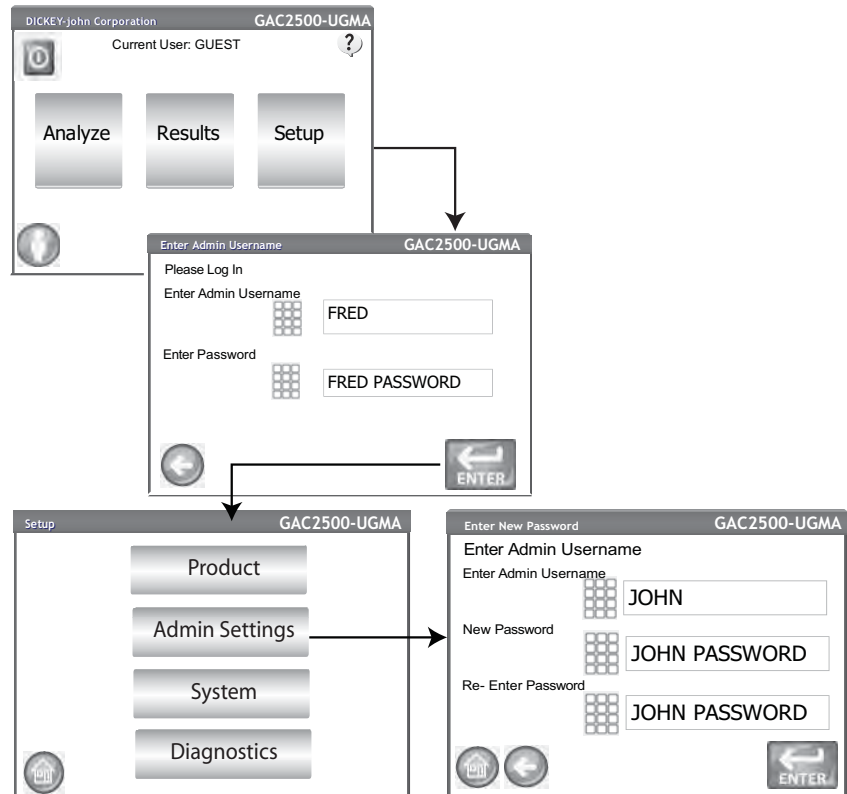
### TO CHANGE A KNOWN USER NAME/PASSWORD

1. At the Main Menu screen, press the **Setup** button.
2. At the Password Login screen, enter existing user name and password.
3. Press the **Enter** button to accept.
4. At the Setup screen, press the **Admin Settings** button.
5. Press the Admin Settings button to display the Admin Settings screen.
6. Press the keypad icon and enter a new Admin Username.
7. Enter New Password and re-enter password for verification.
8. Press the **Enter** button to accept changes.

The new user name and password is saved when the **Enter** button is pressed.

*Figure 23*

#### *Reset Username and Password*



Contact DICKEY-john Tech Support or a local representative to reset instrument to open access mode.



## SYSTEM SETUP

System Setup allows customization of the unit's functionality and print settings:

- Printer/scale setup
- Language selection
- Locale selection
- Time and date setup
- Test result settings (automatic, manual return)
- Exporting data format (CSV, Excel)
- Units of measurement
- Sample setup (sample, user ID)
- Owner data (troubleshooting information)
- Service information (technician information)
- Delete database records
- Check scale
- Network setup (technician recommended)
- Update instrument (technician recommended)

## PRINTER SETUP

A USB or RS232 serial port connection is available to connect a printer that prints test data results to a ticket. Streaming data serially is an option when using the USB printing function.

The ticket can be customized to include details as it relates to facility, date, time, testing errors, and product results. The unit can be set to automatically or manually print a ticket at the end of each test.

*NOTE: Reference the printer's specifications for correct settings.*

### To Set Printer Settings:

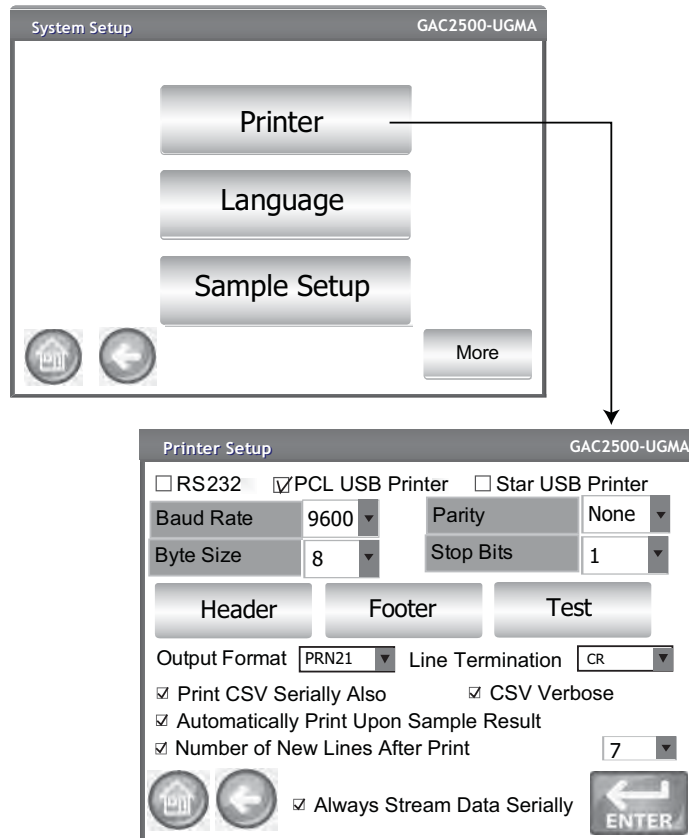
1. At the System Setup screen, press the **Printer** button.
2. At the Printer Setup screen, enable the check box for the type of connection between the unit and printer:
  - RS232 connection using a Null modem cable
  - PCL USB when connecting to a PCL USB printer
  - Star USB when connecting to an SP712 USB printer
3. For an RS232 connection, select the Baud Rate, Byte Size, Parity, and Stop Bits that match the printer.
4. When sending results to a printer, a Header and Footer can be added to print on each ticket, if desired. Refer to Adding a Header/Footer section.
5. Press the **Test** button to verify that the printer and/or computer and the unit's print settings match for proper communication between the devices.
6. When enabled, **Automatically Print Upon Sample Result** will print a ticket at the end of each test.
7. When enabled, **Include Line Feeds After Print** allows additional line feeds to be added at the end of each ticket after printing.
8. Streaming data serially sends data serially when USB is selected. Refer to the Streaming Data Serially selection.



**NOTE:** When printing to a database using an RS232 connection and CSV printer output format, a line feed of 1 is required for a carriage return/line feed.

9. Select the output format.
  - PRN20 - Standard 20 column printer output
  - PRN21 - Special 20 column printer output
  - PRN80 - Standard 80 column printer output (80 characters per line)
  - PRN81 - Standard 80 column printer output (81 characters per line)
  - CSV01 - Comma separated variables (requires a 9600 baud rate) selected when test results are sent to a computer.
  - NTEP - A detailed printout that includes engineering data and test results used by the National Conference on Weights and Measures.
10. Select the line termination style.
  - CR - Carriage return
  - CRLF - Carriage return, line feed
  - LF - Line feed
  - LFCR - Line feed, carriage return

*Figure 24*  
*Selecting a Printer Type*





*NOTE: An external keyboard, barcode scanner, or mouse can be used to enter header and footer information.*

## ADDING A HEADER AND FOOTER TO TICKET

Header and Footer text can be added to print on a print ticket. Owner Data text can be selected as the default or customized text can be entered.

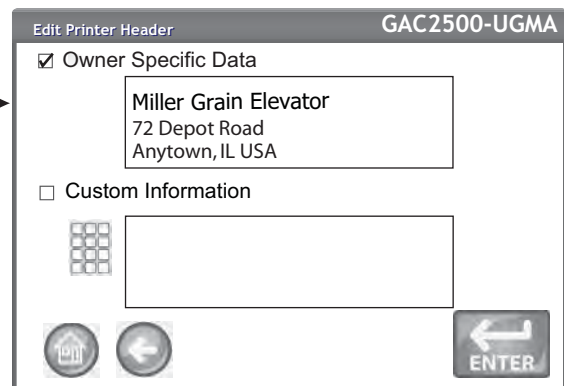
### To Enter a Header/Footer:

1. At the Printer Setup screen, press the **Header** button.
2. To use the Owner Data address information, enable the check box next to the company name and address. If the owner data text box is blank, owner data information has not been entered at the Owner Data screen and can be entered at the System Setup screen, **Owner Data** button.
3. To enter other text, deselect the Owner Data check box.
4. Press the keypad icon on the screen of the lower text box to open the unit's keyboard and enter desired text.
5. Press the **Enter** button to accept.
6. If desired, enter a footer name by pressing the **Footer** button. Enter desired information to appear in footer.

*Figure 25*

*Header Screen*

Entered at  
Owner Data →  
screen



## STREAMING DATA SERIALLY

Streaming data is available in two methods:

### Print CSV Serially Also

When only this feature is enabled, CSV data is transmitted out of the serial port when the **Print** button is pressed along with a print receipt.

### Always Stream Data Serially

When the above "Print CSV Serially Also" is enabled, the optional feature "Always Stream Data Serially" appears onscreen. With this option enabled, data is always transmitted serially out the serial port to an external system whether the Print button is pressed or not.

Both printing and streaming data can be enabled to perform both functions simultaneously or act independently, if desired.

### Enable Data Streaming:

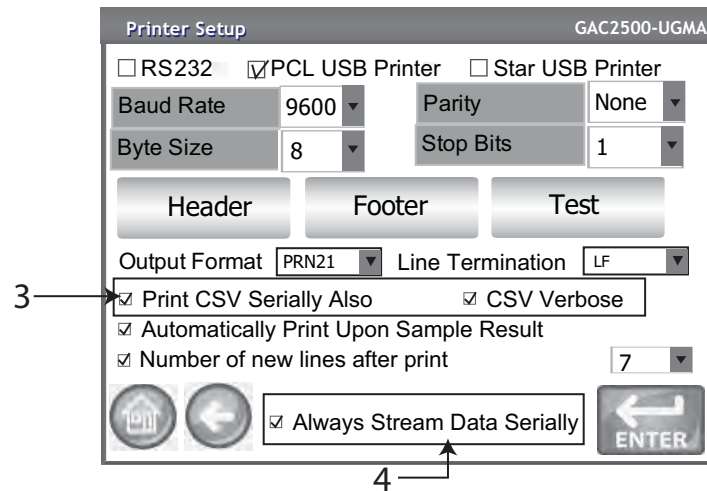
1. At the System Setup screen, press the **Printer** button.



2. Select either USB Printer option.
3. To print to a strip printer and CSV serially, select the “Print CSV Serially Also”.
4. To always stream data serially after each test, select the “Always Stream Data Serially” option.

Figure 26

### Enable Data Streaming



## PRINTER/SCALE SETUP

The GAC 2500 can be set to print test data results to a ticket via a printer as well as interface with a scale. To interface with a printer and scale certain parameters must be selected on the Printer Setup screen:

1. At the System Setup screen, press the **Printer** button.
2. Baud Rate must be set at 9600 to communicate with a scale. At the Printer Setup screen verify the Baud Rate of 9600 is selected.
  - The RS232 checkbox must be selected to view the Baud Rate.
3. To interface with a printer and scale, check either the PCL or Star USB checkbox.
  - When the USB box is checked, the unit can output to both the USB and RS232 port. The USB port communicates with the printer and can operate with any printer output format (step 5).

**IMPORTANT: When the output desired is to a scale and a printer via USB, Print CSV Serially Also and a Baud Rate of 9600 must be selected.**

4. To interface with a scale only, check the RS232 box.
5. Select the output format for the printer.
  - PRN20 - Standard 20 column printer output
  - PRN21 - Special 20 column printer output
  - PRN80 - Standard 80 column printer output (80 characters per line)
  - PRN81 - Standard 80 column printer output (81 characters per line)
  - CSV01 - Comma separated variables (requires a 9600 baud rate) selected when test results are sent to a computer.



*NOTE: When printing to a database or scale using an RS232 connection and CSV printer output format, a line feed of 1 is required for a carriage return/line feed.*

- NTEP - A detailed printout that includes engineering data and test results used by the National Conference on Weights and Measures.
- 6. Select the line termination style.
  - CR - carriage return
  - CRLF - carriage return, line feed
  - LF - line feed
  - LFCR - line feed, carriage return
- 7. When enabled, **Automatically Print Upon Sample Result** will automatically print a ticket at the end of each test. When disabled, a ticket must be manually printed at the end of each test.
- 8. When enabled, **Include Line Feeds After Print** allows additional line feeds to be added at the end of each ticket after printing.
- 9. Press the **Enter** button to accept changes.

## LANGUAGE AND KEYBOARD SETTINGS

Language availability depends on the model type. Language default is English (US).

The GAC 2500-UGMA is equipped with 2 languages that displays the user screens in the language selected.

- English
- Spanish

The GAC 2500-INTL is equipped with 17 languages that displays the user screens in the language selected.

- Brazilian Portuguese
- Czech
- Danish
- Dutch
- English
- French
- German
- Hungarian
- Italian
- Polish
- Portuguese
- Romanian
- Russian
- Serbian
- Slovak
- Spanish
- Swedish

## VIRTUAL KEYBOARD

A **keypad** icon appears on those screens that require text entry. Pressing the Keypad icon opens the virtual keyboard for typing text on the screen. Two keyboard styles are available:

- Qwerty (default)
- Standard

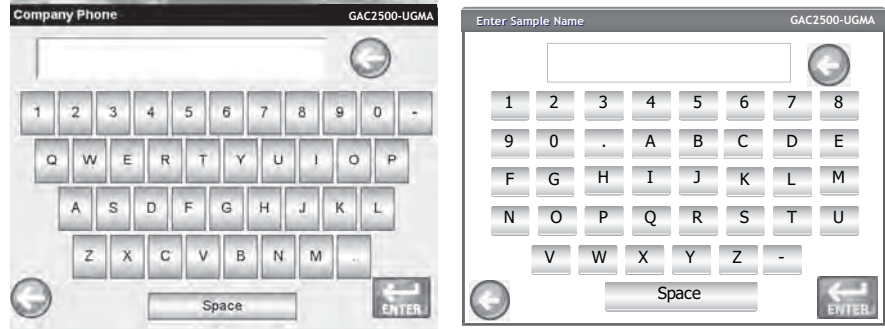




**IMPORTANT: Any text entered using the keyboard appears in English only.**

Figure 27

*Qwerty and Standard Keyboard Styles*

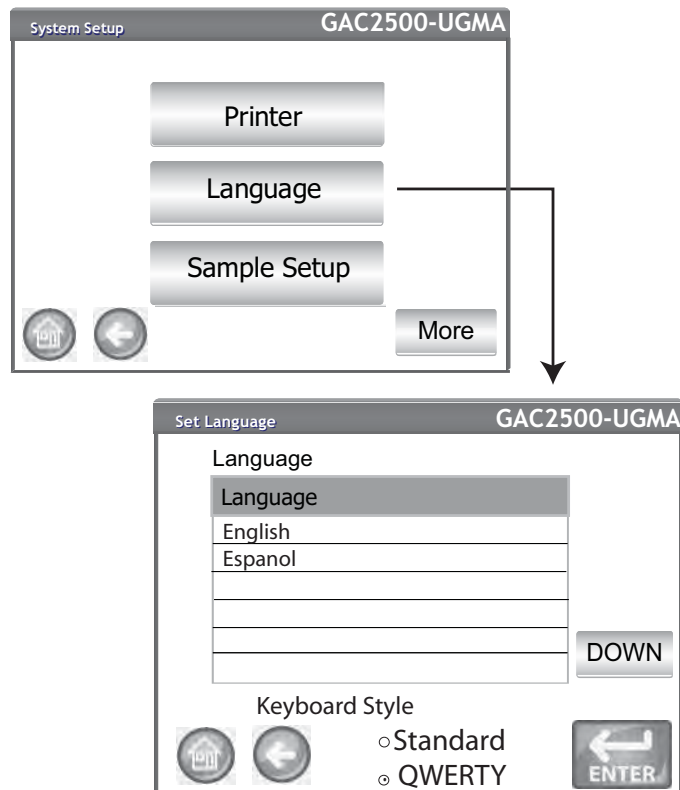


**To Select a Language or Keyboard Type:**

1. At the System Setup screen, press the **Language** button.
2. At the Language screen, press the desired language and press **Enter**.
3. To select a keyboard type, press the radio button to enable either QWERTY or Standard style.
4. Unit automatically converts to the selected system language and/or the selected keyboard.

Figure 28

*Language Screen*





## SAMPLE SETUP

A Sample ID, Customer ID, User Name (Login) can be enabled so that a grain sample is identified and saved with this information each time a test is performed.

1. At the System Setup screen, press the the **More** button until the **Sample Setup** button appears.
2. Enable the check box of desired ID's required when running samples.
3. Press the **Enter** button to accept.

### Prompt for Sample ID

The Sample ID screen step can be hidden so that the screen does not appear during analyzation. If a sample or customer ID is required, "Prompt for Sample ID", should be checked.

Prompt for Sample ID can be enabled even when a sample or customer ID is not required so the screen appears during analyzation giving the option to include either of these ID's.

- Enable when a sample or customer ID are required entries before analyzation. A sample ID will be associated with each grain test and prints to ticket.
- Disable to eliminate the Sample ID screen before each analyzation

### Sequence Sample ID

Automatic number sequencing to the next higher number will occur with additional tests of the same grain. Sequence Sample ID default is enabled.

### Customer ID Required

Requires a Customer ID to be associated with each grain test and prints to ticket. Customer ID default is disabled.

### User Login Required

A User Login requires a tester to login with a user name at the Main Menu screen before grain can be analyzed. If a user login is required, the user name entered at the User Login screen is recorded in the unit's database and prints on the print ticket. The **User** button only appears on the Main Menu screen when enabled. User Login default is disabled.

### Automatic Measure When Hopper is Full

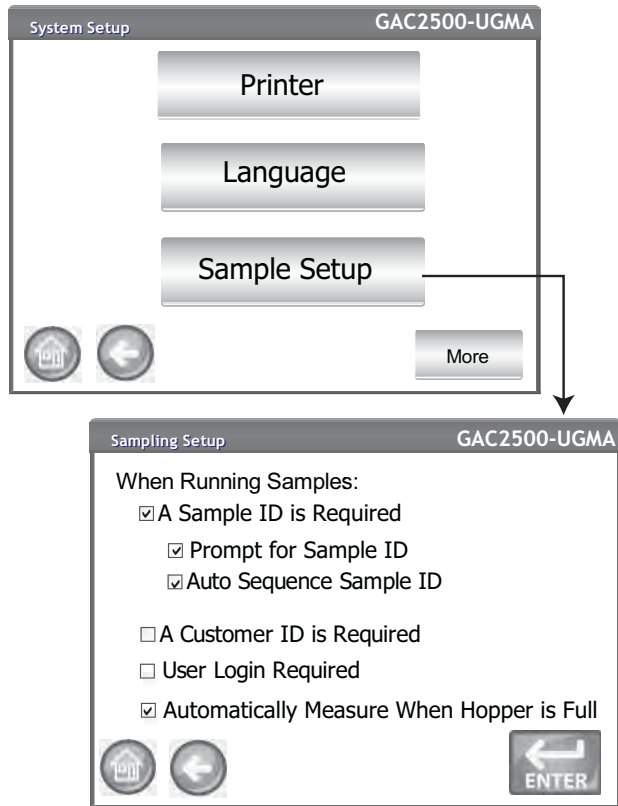
Instrument automatically proceeds to measure a sample when the hopper is full eliminating the need to press the **Initiate** button (green).

- Enable this feature to automate the measuring process. If a Sample ID or Customer ID is required, analysis automatically starts at the Sample ID screen. After the ID requirement is met, the measurement automatically starts.
- Disable this feature to require a manual response at each analysis screen.





Figure 29  
Sample Setup Screen





## RESULT SETUP

After performing a grain analysis, the unit can be set to automatically advance back to the Sample ID screen from the Analysis Results screen or manually return to this screen with a button press. The unit default is set to manual return. Grain automatically dumps from the hopper in manual or automatic advance mode.

### To Display the Sample Return Setup screen:

1. At the System Setup screen, press the **More** button to display and press the **Result Setup** button.
2. Select the desired feature to enable.



### Automatic Return

Advances from the Analysis screen to the Sample ID screen within a specified period of time (4 to 20 seconds) without pressing the **Initiate** button.

### Manual Return

Advances to the Sample ID screen to perform another test by pressing the **Enter** button after each test.

### Empty Drawer Requirement

A forced empty of the drawer requires a sample dump before proceeding to the next analysis.

### Bottomless Drawer in Use

Must be enabled when the bottomless drawer style is used with a flow-through counter to prevent an empty drawer caution from occurring when running tests.

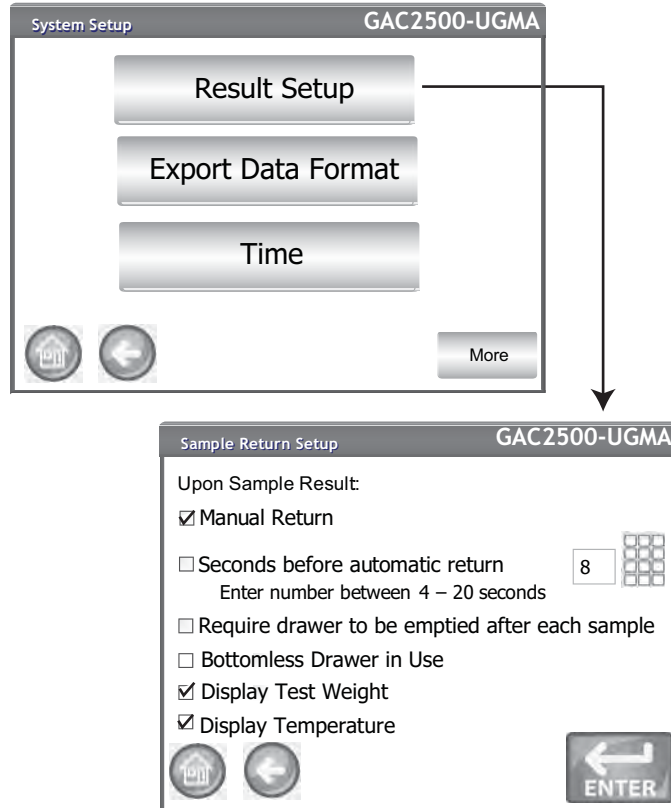
- Grain can also be tested without the grain drawer secured in the unit when Bottomless Drawer in Use is enabled; however, a Drawer Ignored screen appears each time a test is performed and will only proceed to perform test when the **Initiate** button is pressed.

### Display Test Weight and Temperature

Displays the test weight and temperature on the Results screen for each test. Both features are defaulted to enabled.



Figure 30  
Result Setup Screen





## EXPORT DATA FORMAT

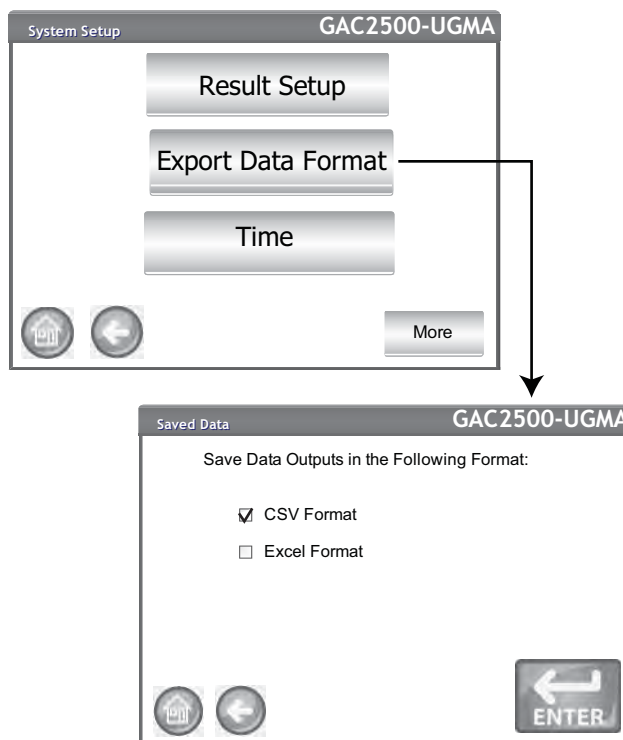
Data can be saved for output to a computer in an Excel or CSV format. The unit default is CSV.

1. At the System Setup screen, press the the **More** button until the **Export Format** button appears.
2. Enable the check box of the desired output.
3. Press the **Enter** button to accept.

**IMPORTANT: A USB memory devices less than or equal to 2GB in size formatted as FAT is recommended for extracting data from instrument.**

*Figure 31*

*Data Format Screen*





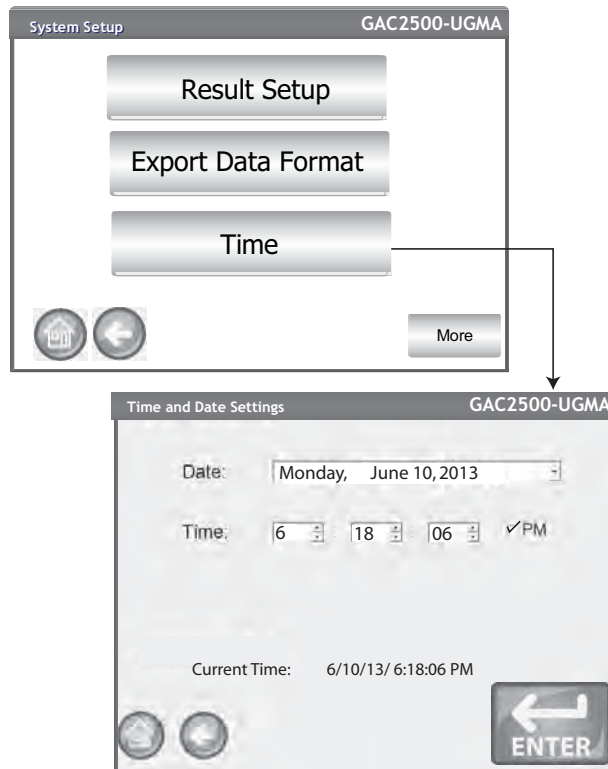
## TIME

*NOTE: The date can be changed to US or UK format at the Units screen.*

1. At the System Setup screen, press the **Time** button.
2. To select a date, press the Date drop down arrow to display calendar.
3. Use arrows to change the month.
4. Enter time using the up/down arrows.
5. Select PM check box, if applicable.
6. Press the **Enter** button when done.

*Figure 32*

*Time and Date Screen*





## UNITS

The Units screen allows selection of:

- Date format (US or Euro)
- Temperature (degrees F or C)
- Unit measurement for test weight (lb/bu or kg/hl)
- Radix point ( , or .)
- Moisture, test weight, and temperature display resolution (tenths or hundredths)

Test Weight defaults to display on the Analysis Results screen but can be removed by disabling at the Sample Setup screen.

### Unit defaults:

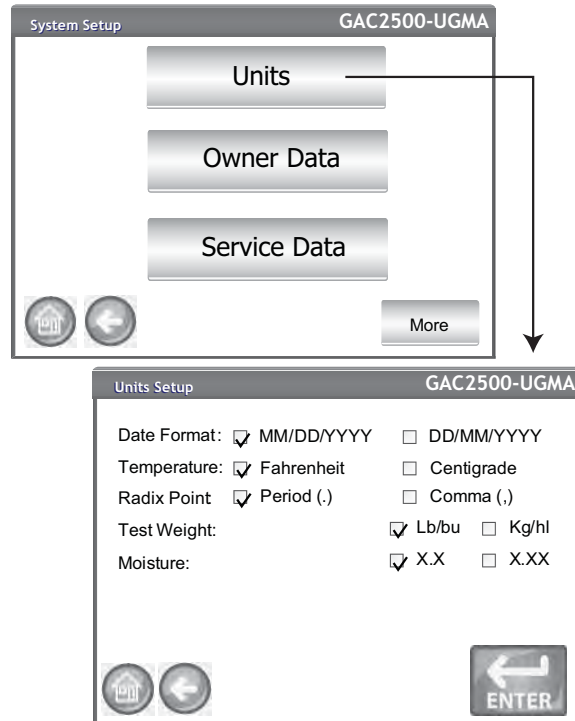
- Date (US - MM/DD/YYYY)
- Test weight (lbs/bu)
- Temperature (degrees F)
- Radix point (Period - .)
- Moisture (tenths)

### To Change Units:

1. At the System Setup screen, press the the **More** button until the **Units** button appears.
2. Press the **Units** button to display the Units Setup screen.
3. Enable the respective check boxes.
4. When selected, press the **Enter** button to accept.

Figure 33

Units Screen





## OWNER DATA

Enter name, address, and phone information, if desired. Data entered at this screen can be used as the header/footer on a print ticket.

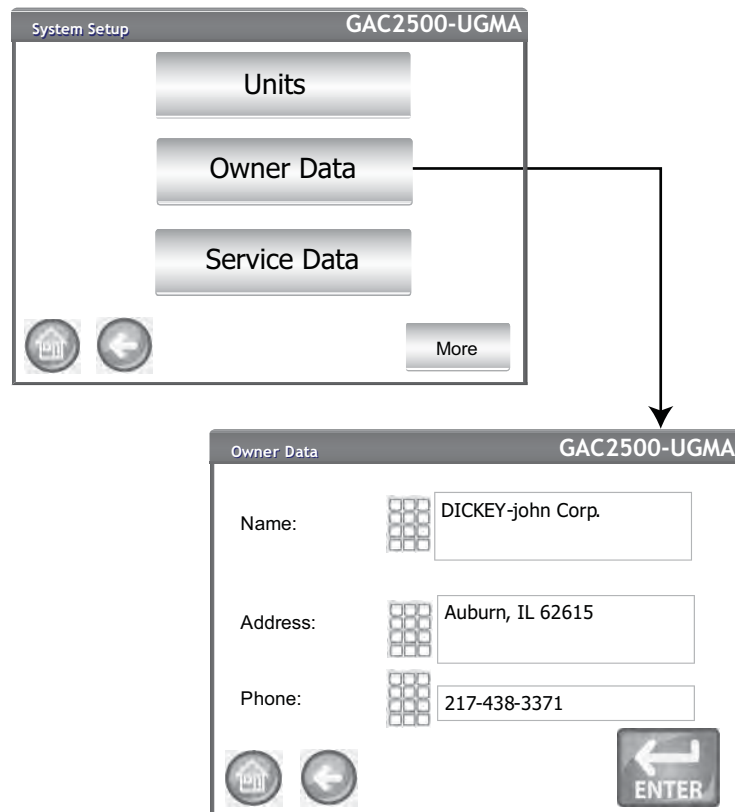
This data can also be viewed by pressing the **Instrument Information** button found on the Main Menu screen, refer to Printer Setup.

1. At the System Setup screen, press the **More** button until the **Owner Data** button appears.
2. Press the **Owner Data** button and enter name, address, phone number by pressing the keypad icon.
3. Press the **Enter** button when finished.



**NOTE:** An external keyboard, barcode scanner, or mouse can be used to enter data.

*Figure 34*  
*Owner Data Screen*





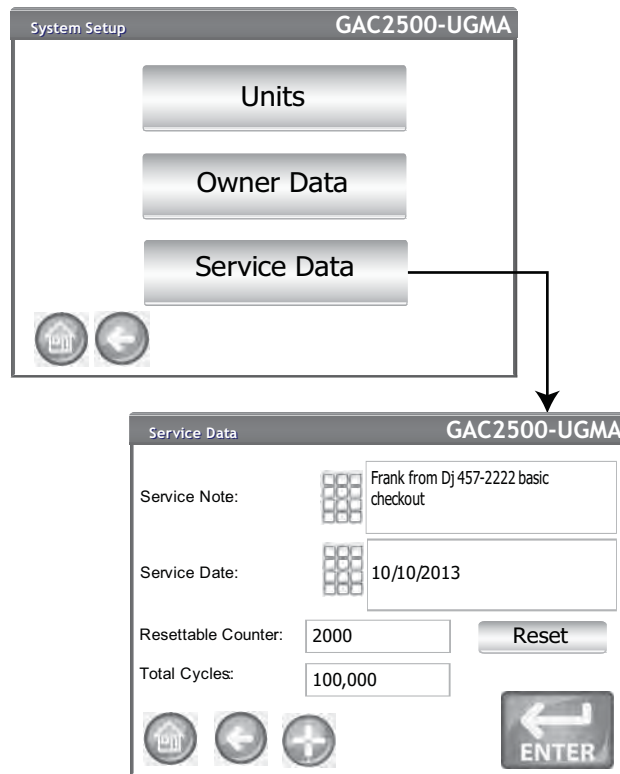
## SERVICE DATA

The Service Data screen provides text entry fields for technicians to enter comments regarding service performed on the unit and service date.

- Resettable Counter resets the number of tests to 0.
  - Total Cycles indicates the number of tests performed over the life of the unit and is not resettable.
1. At the System Setup screen, press the **More** button until the Service button appears.
  2. Press the **Service Data** button to display the Service Data screen.
  3. Enter notes and date by pressing the keypad icon.
  4. Press **Reset** button to set counter to 0, if desired.

*NOTE: An external keyboard, barcode scanner, or mouse can be used to enter data.*

*Figure 35  
Service Screen*





## LCD DISPLAY TOUCH SCREEN CALIBRATION

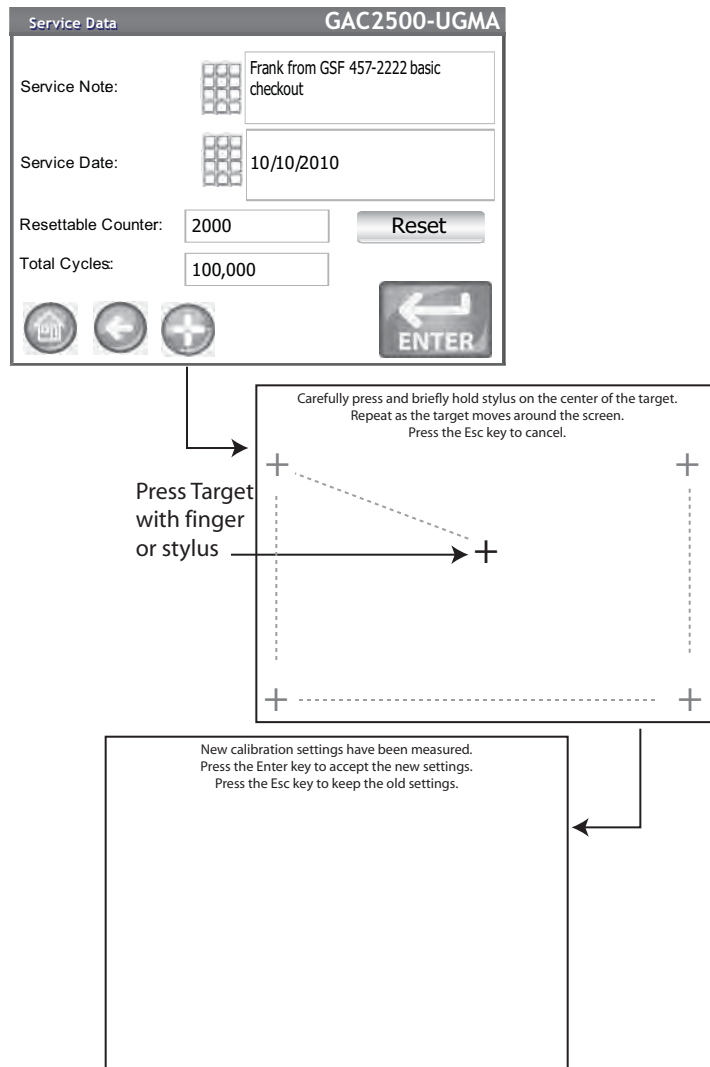
The LCD display touch screen may not respond as it should with a finger touch or stylus after a period of time or if subjected to extreme temperature changes. The display can be re-calibrated to improve responsiveness.



1. At the Service Data screen, press the **Display Touch Screen Calibration** button and follow onscreen instructions.
2. Carefully press and hold finger on the center of the target.
3. Repeat as the target moves around the screen.
4. With a keyboard attached, press the **Enter** button to accept new settings or the **Esc** button to keep previous settings. Without an attached keyboard, press anywhere on the screen to accept.

*Figure 36*

*Display Calibration*





## DATA STORAGE CAPACITY

The unit is capable of storing a maximum of 3,000 test results. The database can be cleared at any time by selecting the **Clear Database** button located under the System Setup screen. When stored data has reached approximately 2,500 records, a warning screen automatically appears when attempting a grain measurement that indicates memory capacity is getting low. Analysis can still occur until the maximum allowed records of approximately 3000 is reached. Once maximum storage is reached, grain analysis cannot continue until cleared.

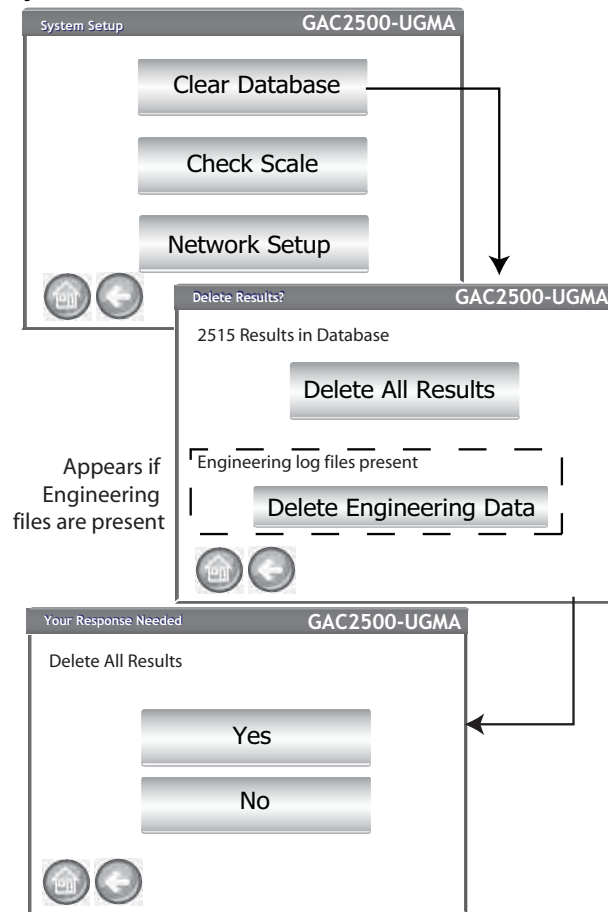
*NOTE: Records cannot be exported to a USB memory device at this screen. If a backup is required, this can be accomplished at the View Results screen found under the Results button.*

### To Delete Records:

1. At the System Setup screen, press the **More** button until the **Clear Database** button displays.
2. Press the **Clear Database** button to display the Delete Results screen.
3. At the Delete Results screen, press the **Delete All Results** button.
  - A Delete Engineering Data button appears if Engineering log files are present. This button must be pressed to clear those records.
4. Press **Yes** to proceed with clearing records.
  - Press **No** to abort record deletion.

*Figure 37*

*Memory Capacity Low Screen*





## CHECK SCALE

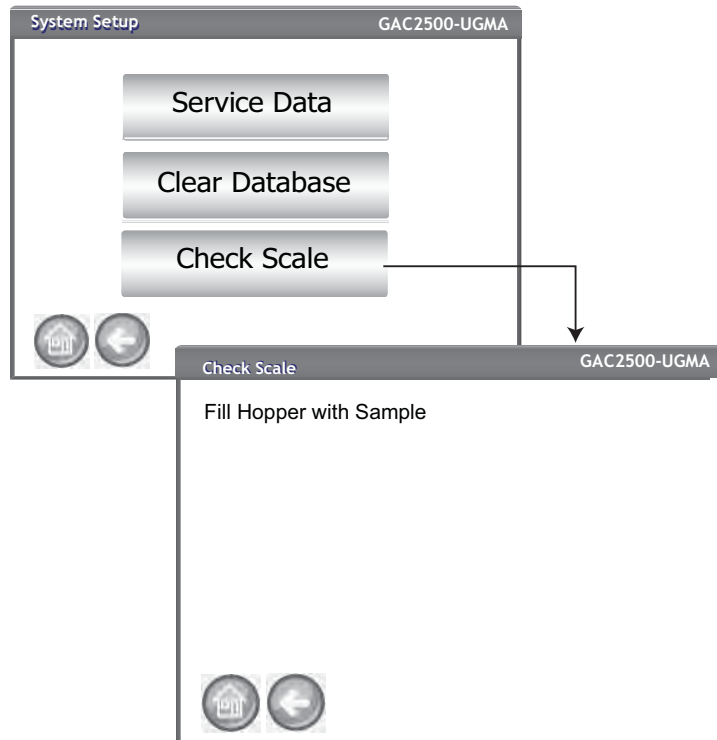
Check Scale performs an instrument scale measurement for a weight accuracy comparison with an external scale. The readings displayed onscreen are actual temperature and weight product results.

### To Perform a Check Scale:

1. At the System Setup screen, press the **More** button until the **Check Scale** button displays.
2. Press the **Check Scale** button to display the Check Scale screen.
3. Fill hopper with a sample. When the hopper is full, the next screen automatically displays.

*Figure 38*

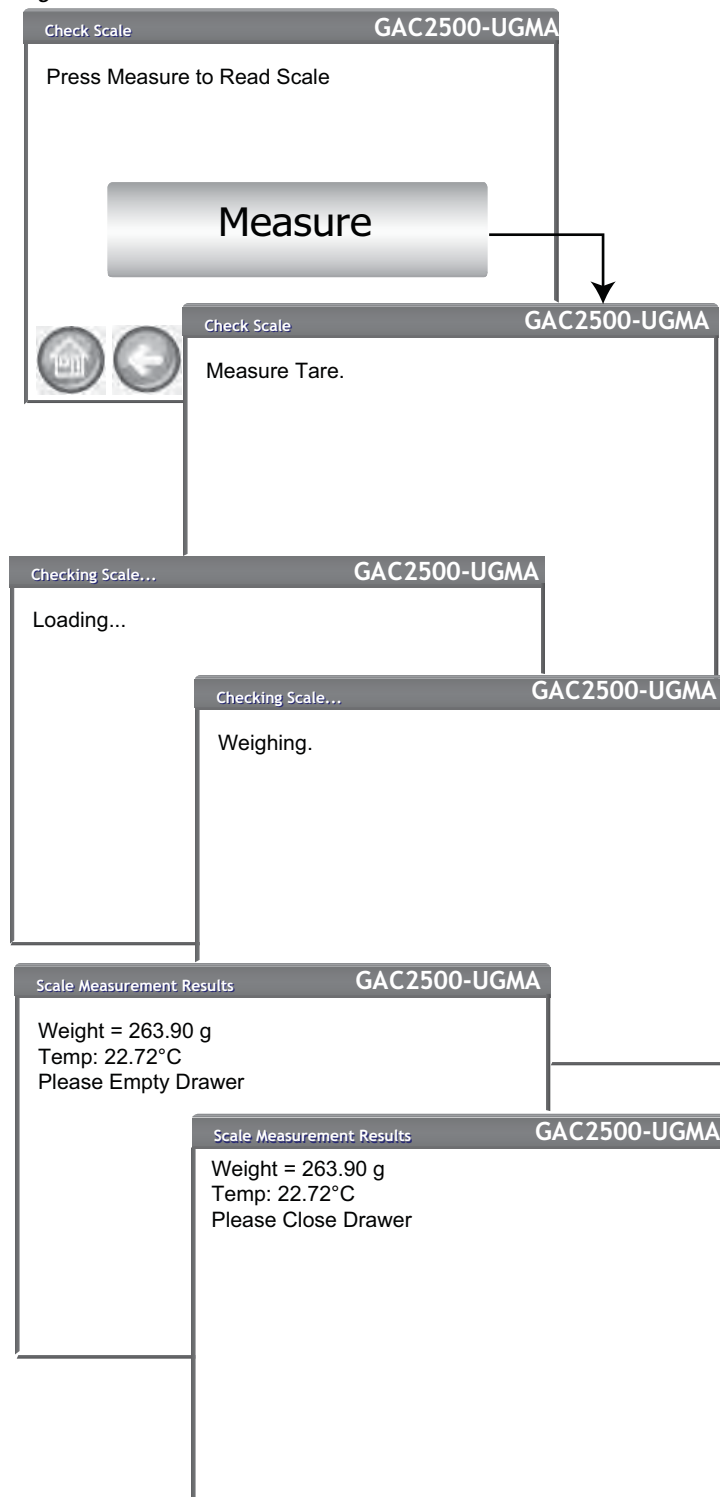
*Performing a Check Scale*



4. Press the **Measure** button to start the process.
  - This is the last screen that allows returning to the previous screen or returning to the Home screen.
5. Measurement process automatically begins measuring tare then loading and weighing the sample.
6. At the Scale Measurement Results screen, dump any excess material that fell into the drawer during the strike off process. The sample weight and temperature captured during the measurement appears on this screen.
7. Insert drawer into instrument.



Figure 39  
Performing a Check Scale



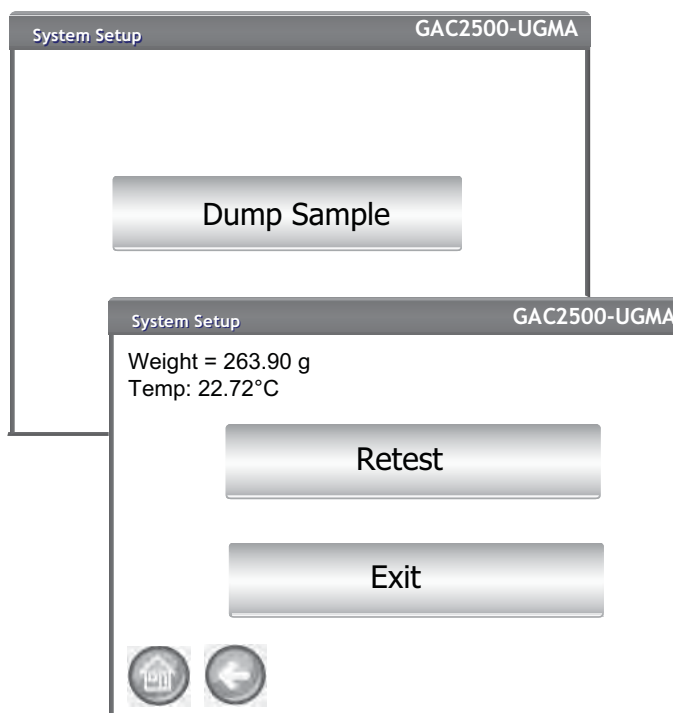
8. Press the **Dump Sample** button to dump sample into drawer.



9. Remove drawer and weigh the grain in the drawer on an external scale and compare to reading on the display.
10. Press the **Retest** button to perform another check scale or **Exit** button to return to the Setup screen.

*Figure 40*

*Dumping Sample*





## NETWORK SETUP

Network setup specifies ethernet settings for the instrument. This feature should be enabled by an authorized service technician or by contacting DICKEY-john Tech Support.

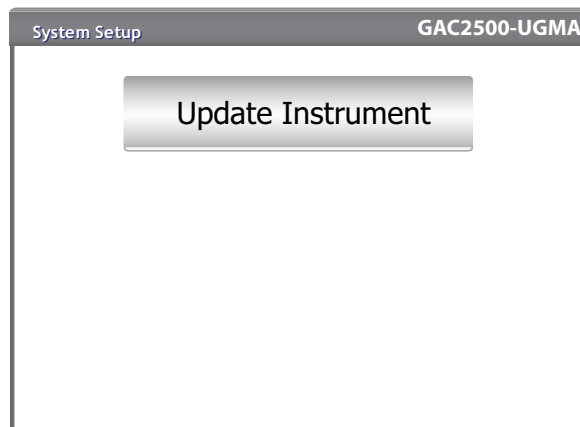
## UPDATE INSTRUMENT

Update Instrument allows a software update to the instrument via a USB memory device. This feature should be enabled by an authorized service technician or by contacting DICKEY-john Tech Support.

*Figure 41*

*Network Setup*

---





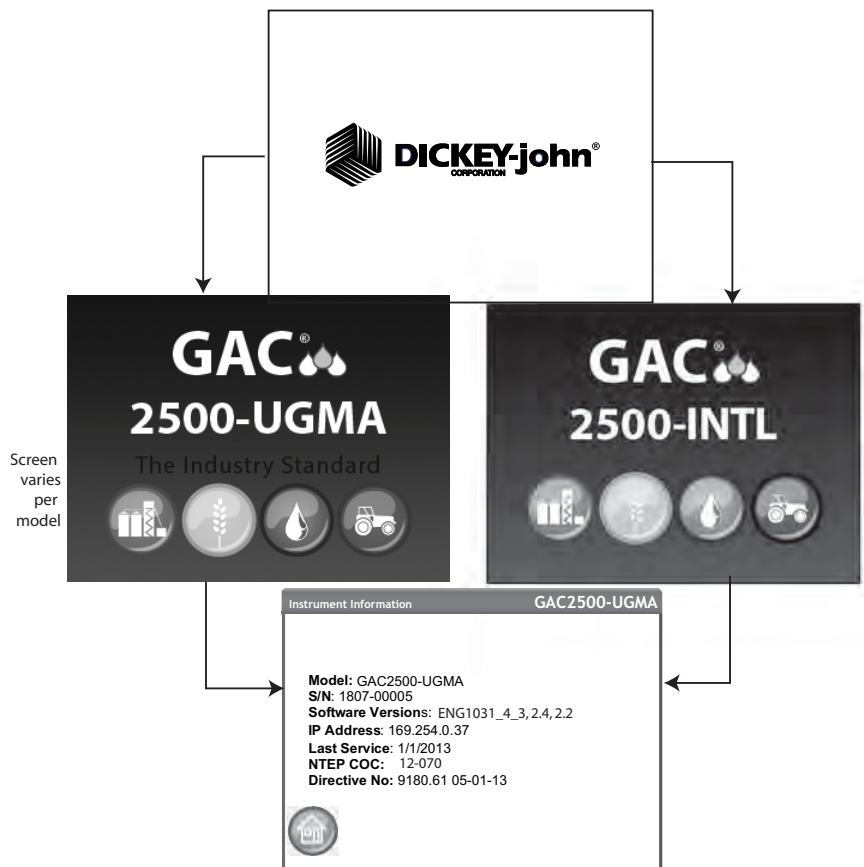


## STARTUP

The GAC<sup>®</sup> 2500 is powered on by pressing the on/off switch located on the front panel (Figure 1). A series of Startup screens load after the system is turned on. A status bar will indicate self checks are occurring and upon completion, the Instrument Information screen displays before the Main Menu screen appears.

**IMPORTANT:** On initial power up of the unit, the system defaults with open access to all screens. To ensure that the unit's settings are protected and accessible by qualified users, an administrative level with password should be created. Refer to the System Setup section for further information.

Figure 42  
Startup Screens





## POWER DOWN

The unit can be powered down from any screen by pressing the on/off switch located on the front panel.

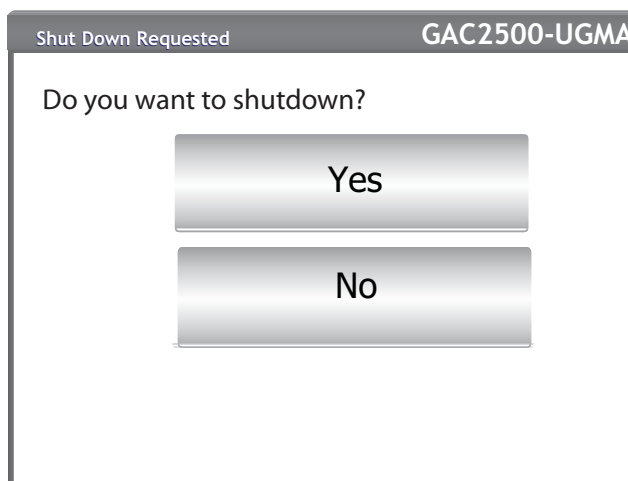
A virtual **Power Down** button is also available on some top level screens and powers off the unit in the same manner as the on/off switch.

A Power Down screen must be acknowledged before the unit shuts down.

*Figure 43*

*Power Down Screen*

---





## ANALYZING GRAIN

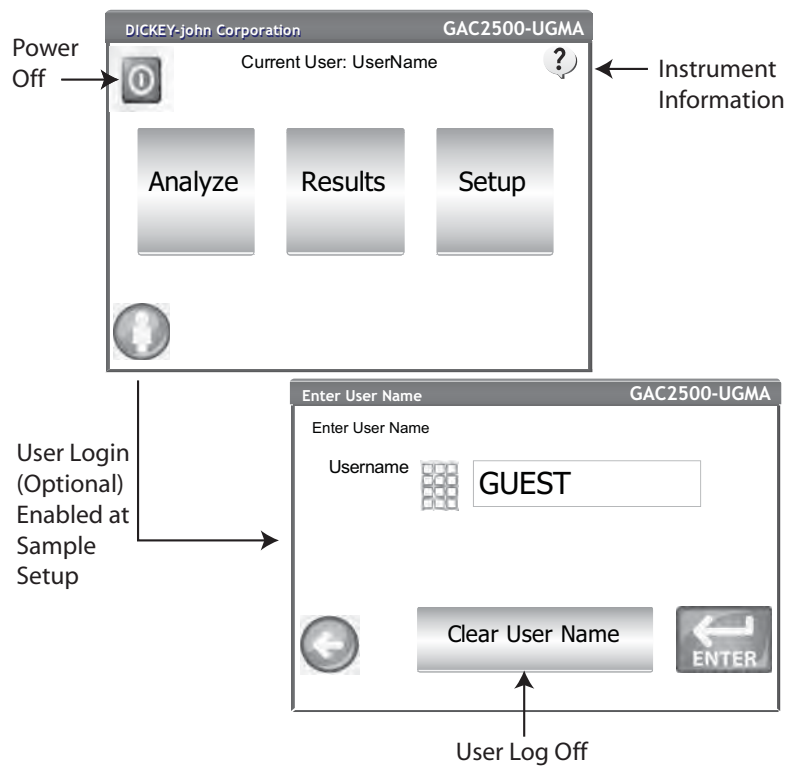
The Main Menu screen appears after all Startup screens have loaded. This is the "Home" menu through which all other menus are accessed.

At the Main Menu screen, three functions are performed:

1. To analyze grain
2. To access test results
3. To setup/customize the unit

Figure 44

Main Menu (Home) Screen



### USER LOGIN (OPTIONAL)



A User Login is an optional feature that requires a user to login before grain can be analyzed. The unit default is no user login required. If a user login is required, a **User** button appears on the Main Menu screen. The User cannot proceed to test grain until a login name is entered. The User Login feature records the user name with a grain test in the unit database and prints on each grain ticket.



**NOTE:** Refer to the *System Setup, Sample Setup* section to enable user login.

## USER LOGIN

1. At the Main Menu screen, press the **User** button.
2. GUEST appears as the default User Name and must be replaced with a different user name. Press the keypad icon to enter a new user name.

Figure 45

User Login Keypad



3. Press the **Enter** button to accept. The user name will appear as the current user on the Main Menu screen.

The unit will continue to analyze grain with the active user name until the user logs off or the power is turned off.

## USER LOG OFF

1. At the Main Menu screen, press the **User** button.
2. At the User Login screen, press the **Clear User Name** button. GUEST will default as the new user name.
3. Press the **Enter** button to return to the Main Menu screen.
4. A new user name must be entered before additional grain analysis is allowed.



## SELECTING PRODUCT

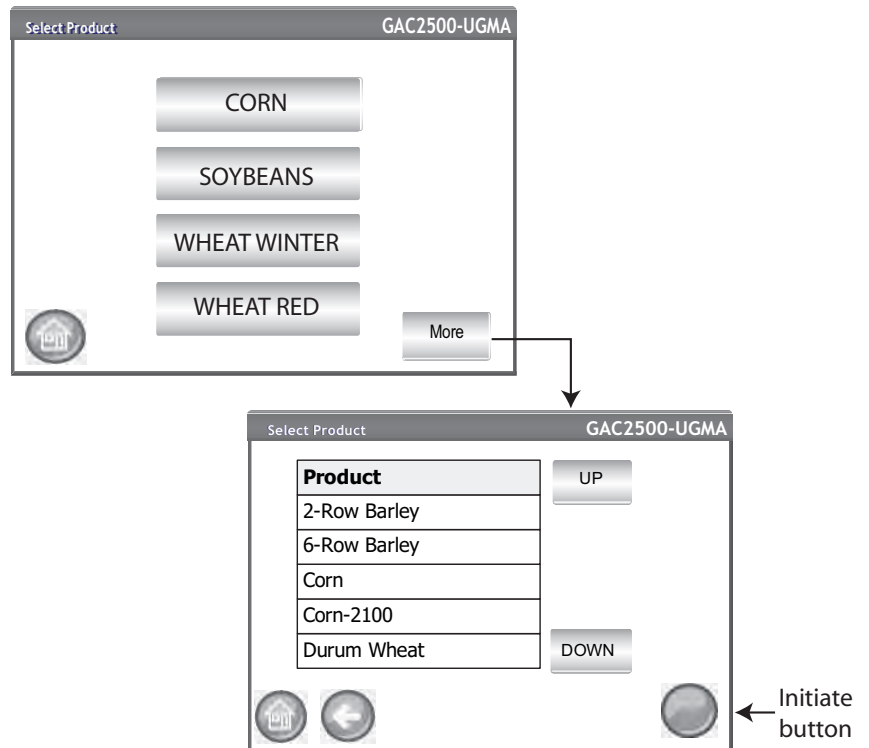
*NOTE: If User ID is enabled, it must be entered before analyzation can occur.*

### To Select a Grain for Testing:

1. At the Main Menu screen, press the **Analyze** button.
2. A pre-defined list of 4 grains appear on the Select Product screen.
  - Grains are saved in a “last used” order.
  - A grain selected on the first Select Product screen proceeds to Sample ID screen or the Analysis screen.
3. To view additional grains not viewable on the top level Select Product screen, press the **More** button.
  - Press the **Up** and **Down** buttons to view grains.
  - Select the desired grain in the product table.
  - Once selected, press the **Initiate** button to accept.
4. Grain is ready for analysis.

*Figure 46*

*Select Product*



## PERFORMING A GRAIN ANALYSIS

Screens that display during analysis will vary based on what configurations are enabled or disabled at the System Setup/Sample Setup screens:

- Automatic grain measurement when hopper is full
- Sample ID and/or Customer ID screen prompt step
- User Login requirement
- Empty drawer requirement after each test



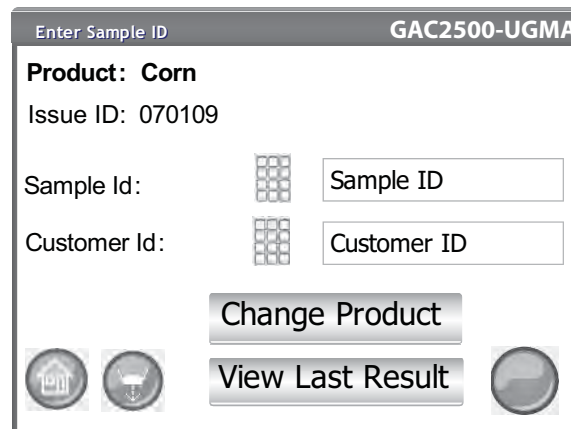
**NOTE:** To eliminate this screen before each analysis, disable at the *Sample Setup* screen.

## To Begin Analysis:

1. If enabled, the Enter Sample ID screen appears. The selected product and Issue ID displays at the top of the screen.
  - **Change Product** button allows selection of a different product.
  - **Dump** button dumps product from the hopper.
2. A Sample ID name can be entered by pressing the keypad located next to the input box.
  - If automatic number sequencing is enabled, the next higher number is automatically entered with additional tests of the same grain (1,2,3, etc). If auto sequence is not selected, the previous tests sample ID is cleared.
3. A Customer ID can be entered by pressing the keypad located next to the input box.
4. Press the **Initiate** button to proceed.
  - If the automatic measure feature is enabled, instrument automatically proceeds.
5. Pour grain into the hopper heaping grain slightly up to the hopper full sensors.

Figure 47

Sample ID Screen



## **CAUTION**

Do not insert fingers or foreign objects into the opened hopper doors.

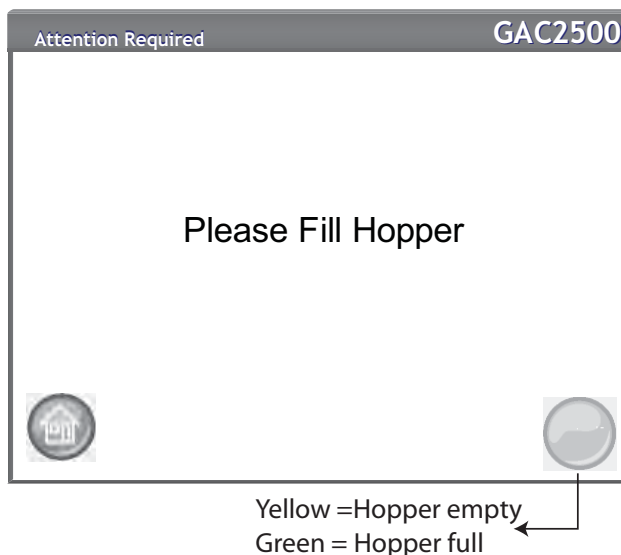
## HOPPER LEVEL INDICATOR

During analysis, hopper level status is indicated via the **Initiate** button.

- Yellow indicates hopper is empty and must be filled before proceeding.
- Green indicates hopper is full and testing can proceed.

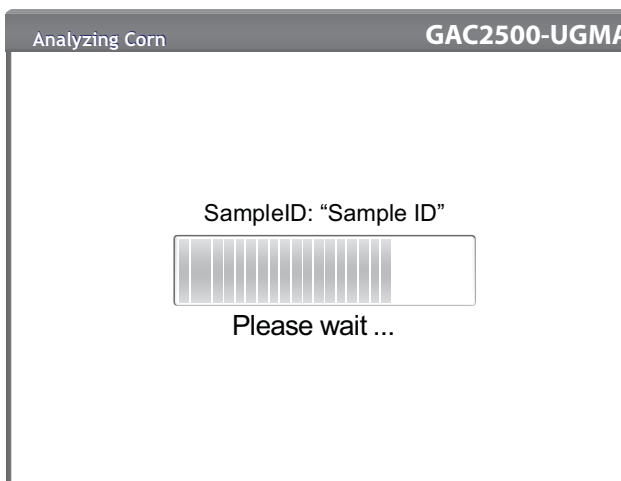


Figure 48  
Hopper Level Indicator



6. Press the **Initiate** button (green) to begin test. Grain will dump into the measurement cell from the hopper. A test will only perform when the **Initiate** button is green.
  - If the automatic measure feature is enabled at the Sample Setup screen and the hopper is full, instrument automatically proceeds to measure a sample skipping the Fill Hopper screen and eliminates pressing the **Initiate** button.
7. The cell fills and the striker arm swings across the top of the test cell to wipe away excess grain.
8. During analysis, a testing status bar indicates progress.

Figure 49  
Analysis Process





*NOTE: To automatically return to the Sample ID screen without pressing the **Initiate** button refer to the System Setup, Results Setting section for enabling Automatic Return.*

9. An audible alarm indicates when test is complete and automatically advances to the Analysis Results screen.

10. The Analysis Results screen displays:

- Product tested
- Sample name
- Moisture content %
- Test Weight lbs/bu or kg/hl (optional)
- Temperature (optional)

11. Test results are automatically saved to the unit.

12. If the unit is set to manual advance after each analysis, press the **Initiate** button to initiate another test.

Grain automatically dumps into the drawer for removal in Manual or Automatic advance.

- A requirement that grain be dumped after each test can be enabled at the Result Setup screen.

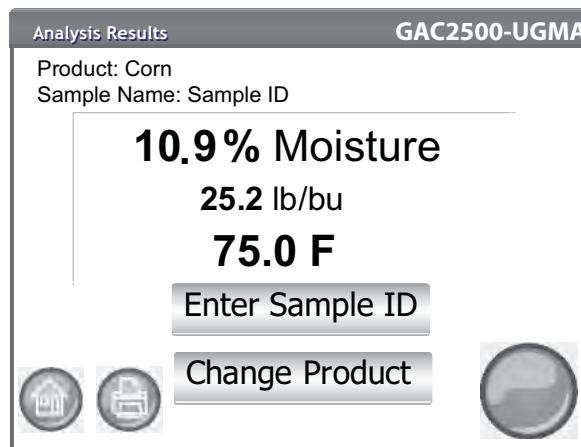
Drawer capacity holds approximately 3 tests. After 3 tests the drawer must be emptied before proceeding.

**IMPORTANT: When using a bottomless grain drawer with flow-through counter, the bottomless drawer feature should be enabled under System Setup, Result Settings to perform unlimited grain tests to eliminate error messages.**

Grain will not dump out of the cell if drawer is not present or secure.

*Figure 50*

*Analysis Screen*



#### Other Actions:

- **Print** button sends test results to a local printer.
- **Home** button returns to the Main Menu screen.
- **Enter Sample ID** button to enter a Sample ID for next analysis. Does not allow changing the current Sample ID.
- **Change Product** button allows quick selection of a new product for analysis.



## GENERAL CLEANING TIP

Some material accumulation around the measuring cell can possibly occur over time and could possibly affect measurement results.

It is recommended the unit be regularly cleaned to ensure continued and consistent results. Refer to the Maintenance section for cleaning steps.

*NOTE: Refer to the Error Message section for probable causes and corrective actions if errors occur during analysis.*

*NOTE: Refer to the Save Results section and Printing Options section for output options.*



## DATABASE MEMORY MESSAGES

### DATABASE MEMORY FULL WARNING

When stored data has reached approximately 2,500 records, a warning screen automatically appears when performing a grain analysis indicating memory capacity is getting low. Analysis can still occur until the maximum allowed records of approximately 3000 is reached.

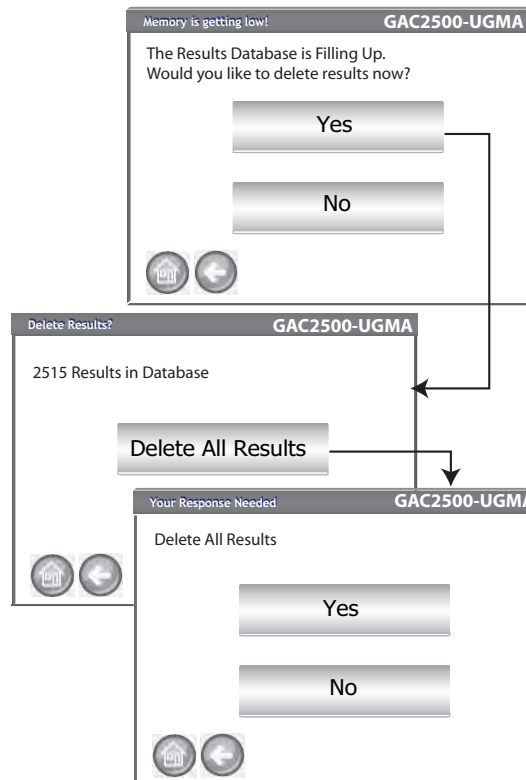
*NOTE: Records cannot be exported to a USB memory device at this screen. If a backup is required, this can be accomplished at the View Results screen found under the Results button.*

#### To Clear Database Records:

1. At the Memory Low screen, press **Yes** to delete results.
  - Select **No** to return to previous screen and abort deleting records.
2. At the Delete Results screen, the number of records in the database is indicated. Press the **Delete All Results** button to confirm record deletion.
3. Press the **Yes** button to verify and begin deleting records.
  - Select **No** to return to previous screen and abort record deletion.

Figure 51

Clear Database Screen



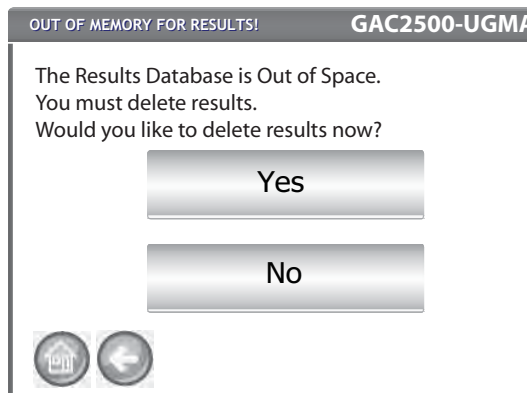


## OUT OF MEMORY

A Database Full screen displays when performing a grain analysis and the database has reached maximum storage capacity. Analysis cannot continue until records are deleted. Follow onscreen instructions to remove records.

*Figure 52*

*Out of Memory*

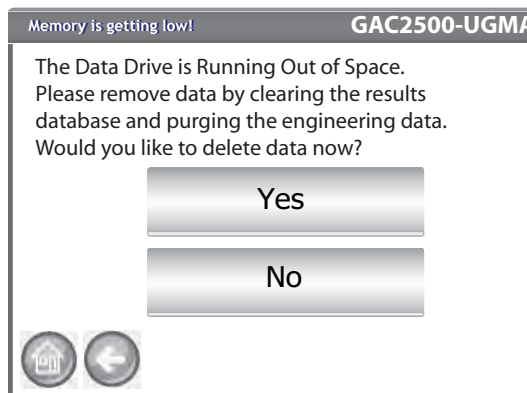


## DATA DRIVE MEMORY LOW

UGMA instruments automatically have engineering data enabled. Engineering data is stored separate from the Results Database. Therefore the Results database can be empty but the Data Drive can exceed capacity causing a memory low error. Analysis can continue but the data drive should be cleared soon.

*Figure 53*

*Data Drive Memory Low Warning*



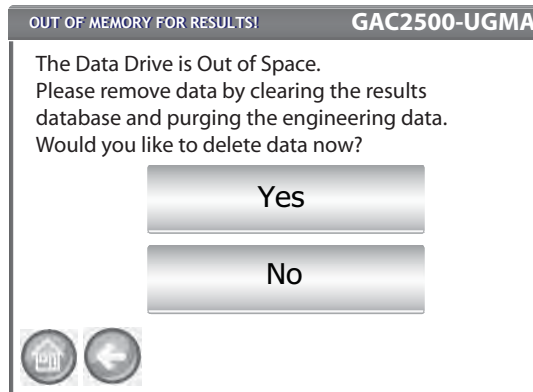


## DATA DRIVE OUT OF MEMORY

A Data Drive Out of Memory screen appears when the data drive is out of space. An analysis cannot be performed until data is cleared.

*Figure 54*

*Data Drive Out of Memory Warning*





## RESULTS

The Results screen provides access to grain test results, product list, and audit trail.

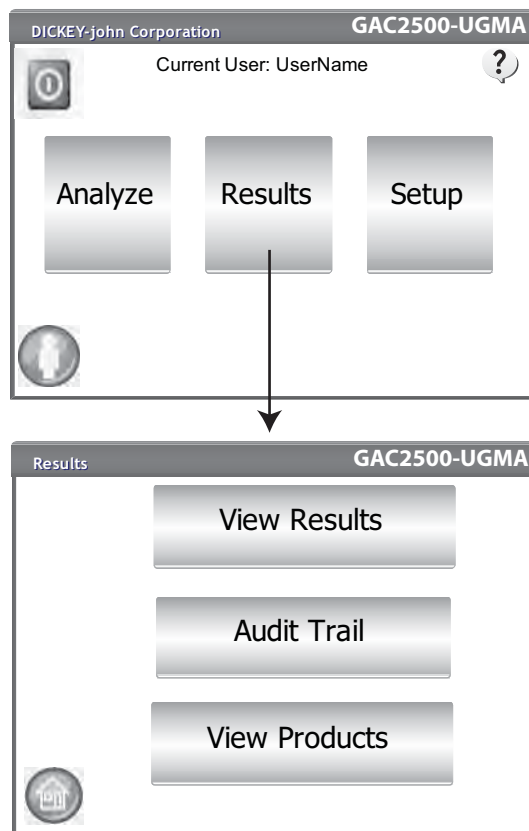
### To View Test Results:

1. At the Main Menu screen, press the **Results** button.
2. At the Results screen, press the **View Results** button.

*NOTE: A momentary pause may occur before test results appear on screen. Do not press any buttons during this time.*

Figure 55

View Results

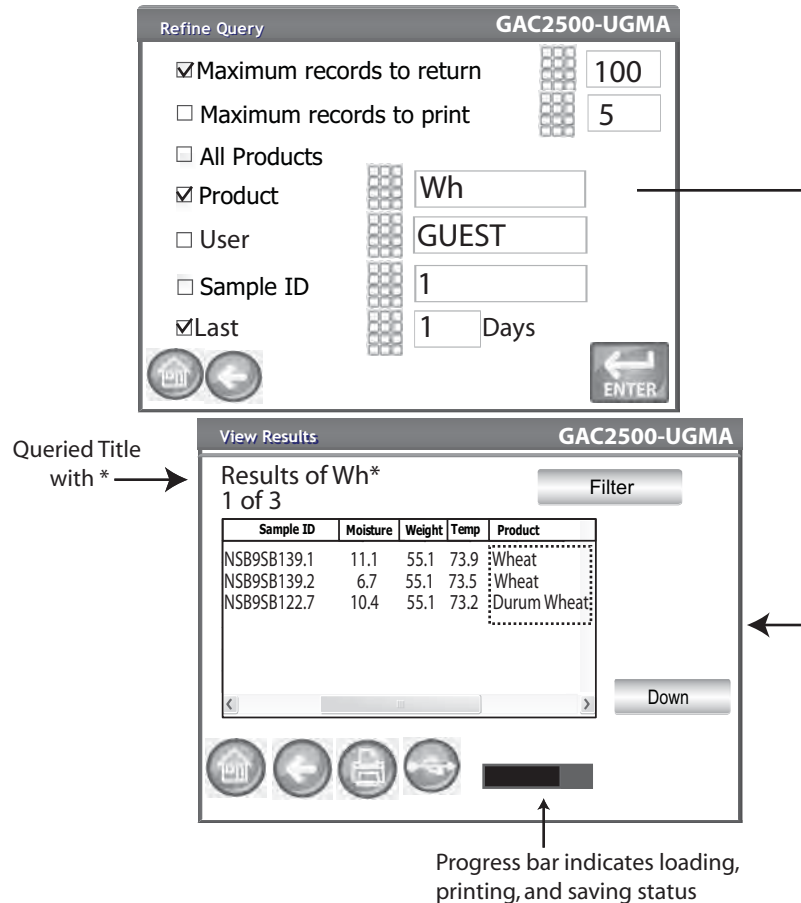


3. The Results screen default displays all test results with Sample ID, % Moisture, Weight, Temperature, Product, Issue No., Customer ID, User ID, Date and Time.
4. Press the **Filter** button to choose what events display on the test results record. Refer to Refine Query Options for criteria options.
5. Press the **Print** button to print results as displayed in the table on the Results screen.
6. Insert USB memory device and press the **USB** button to transfer product results to a computer. All results are transferred to USB regardless of Filter setting.



## REFINE QUERY OPTIONS

Figure 56  
Product Like Criteria Example



Results can be filtered to display based on one or all of the following criteria:

### MAXIMUM RECORDS TO RETURN

Allows entry of a specified number of records to query so that only a specific last number of records are returned. When the Query Only Last option is checked, the title of what is queried will contain an asterisk to indicate that all returned results are displayed per the limit of records entered but there could be more older records in the database that meet the same criteria.

### MAXIMUM RECORDS TO PRINT

Allows entry of a specified number of records to print starting with the last sample taken, such as printing the last 5 samples taken.



*NOTE: A status bar indicates progress of retrieving filtered data. Results can take several minutes to load while retrieving data. Do not press any buttons during this time.*

*NOTE: User and Sample ID filter function works the same as the Product filter. Refer to (Figure 56)*

## ALL PRODUCTS

Displays all sample tests stored on instrument.

## PRODUCT

Allows entry of part or all of the product name to perform a product search. All records that fit criteria entered in the Product Like filter search will display. Example: Searching for a product like "Wh" searches for all records with "Wh" in the product name. (Figure 56) displays results for Wheat and Durum Wheat.

## USER

Allows entry of part or all of the User name to perform a search for similar records within the User field. All records that fit the criteria entered in the User filter search will display.

## SAMPLE ID

Allows entry of part or all of the Sample ID name to perform a search for similar records within Sample ID. All records that fit the criteria entered in the Sample ID filter search will display.

## LAST

Displays the last number of days specified. All records that fit the criteria entered will display.

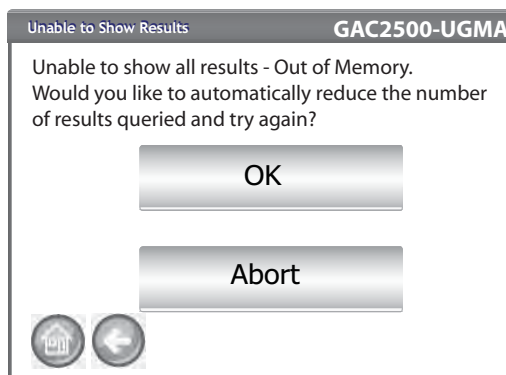
## UNABLE TO SHOW QUERY RESULTS

When the system has reached near memory storage capacity, a query might not be able to display results per the number of records entered on the Query screen. In this instance, a screen confirmation will require the query be performed at a reduced number than was entered on the Query screen.

- Press **OK** to run query at reduced number
- Press **Abort** to cancel and return to Home screen.

*Figure 57*

*Unable to Show Results Screen*





## AUDIT TRAIL

Any changes that relate to system functionality and testing are recorded and stored. The Audit Trail provides a log of these changes.

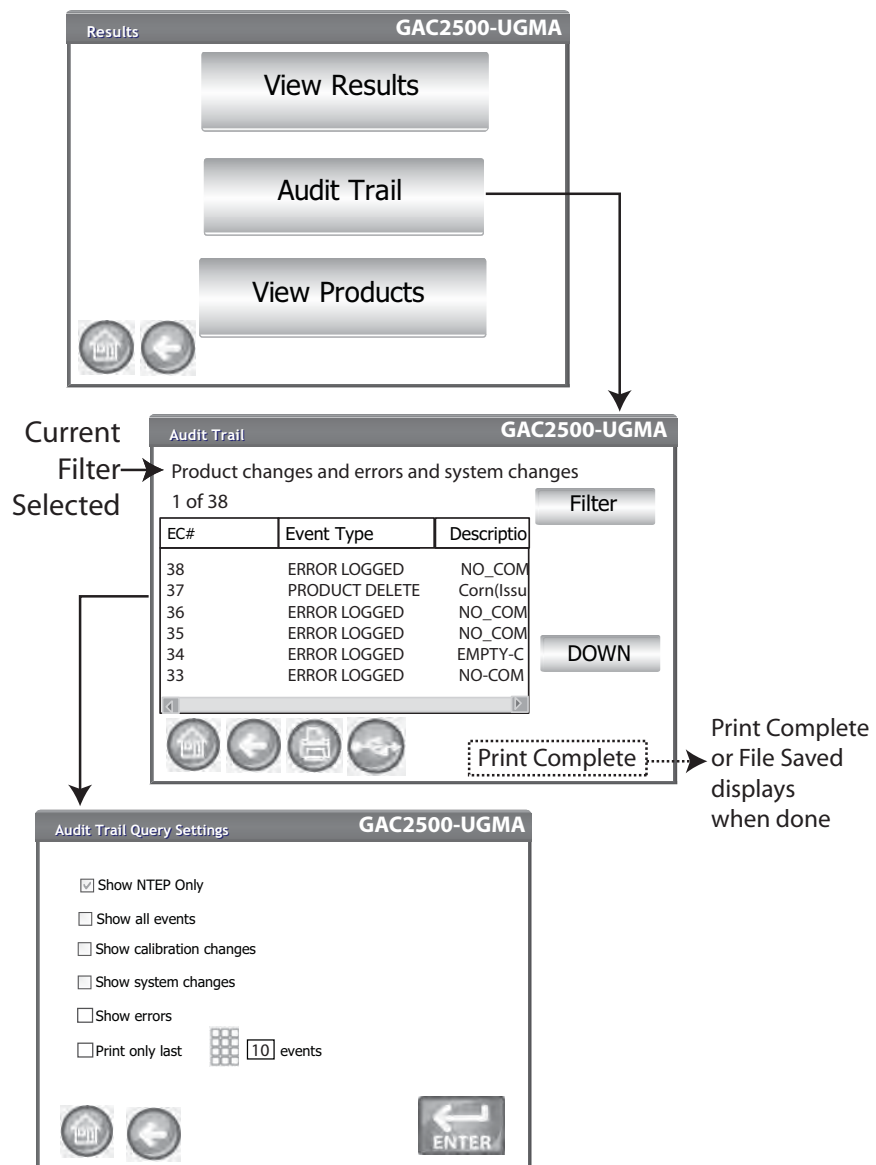
### To View Audit Trail:

1. At the Results screen, press the **Audit Trail** button.
2. The Audit Trail screen displays
  - Event Counter (EC#) (number assigned to each change)
  - Event Type
  - Description
  - User
3. Press the **Filter** button to choose what events display on the Audit Trail record or to obtain an NTEP audit trail display.
  - Show NTEP only (when selected, all other options are unchecked)
  - Show All Events (when selected, all other options are unchecked)
  - Show Calibration Changes
  - Show System Changes
  - Show Errors
  - Print only a certain number of events
4. Press the **Print** button to print results as displayed on the Audit Trail screen. If the printer output format is PRN80, PRN81, CSV01 or NTEP, the output format is CSV. All other formats print in strip.
5. Insert a USB memory device and press the **USB** button to transfer Audit Trail results as displayed on the Audit Trail screen to a file for transfer to a computer.





Figure 58  
Audit Trail





## VIEW PRODUCTS

The Installed Products screen provides an alphabetical table of active products stored on the unit with respective Issue ID. Products can only be viewed and printed at this screen.

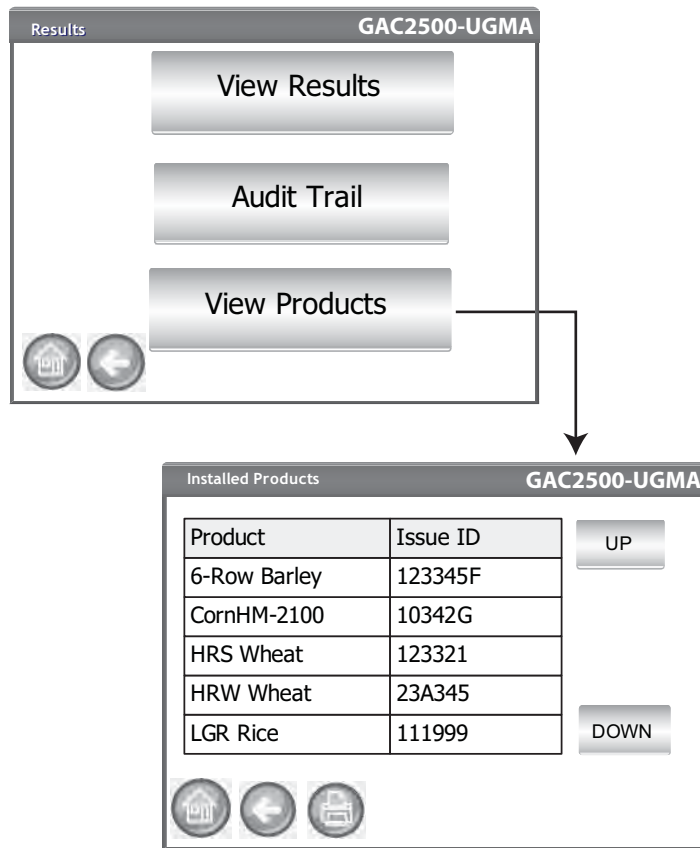
### To View Products:

1. At the Results screen, press the **View Products** button.
2. Press the **Print** button to print all active products and respective Issue ID's.



Figure 59

View Products Screen





## GRAIN CALIBRATIONS

Grain calibration files are available for download at the DICKEY-john website for transfer to the GAC<sup>®</sup> 2500 via a USB memory device.

*[www.dickey-john.com/Products/Analytical/Moisture Testing/GAC2500 Grain Analysis Computer/Get Support/Downloads](http://www.dickey-john.com/Products/Analytical/Moisture%20Testing/GAC2500%20Grain%20Analysis%20Computer/Get%20Support/Downloads)*

These files are also available through DICKEY-john Technical Support Group at 1-800-637-3302.





## DIAGNOSTICS

The Diagnostics screen is typically used by trained service technicians to perform various functions and for troubleshooting purposes. It is recommended that the functions on this screen are performed by a DICKEY-john representative.

### To View Diagnostics Screen:

1. Press the **Setup** button to display the Setup screen.
2. Press the **Diagnostics** button to view the Diagnostics screen.

Figure 60

Diagnostics Screen

**GAC2500 Diagnostic Form - 1807-00630** **GAC2500**

IP:10.30.2.70, 10.30.25.46

WEIGHT:00.07  
IR Temp: 21.76

Open Hopper Door Rehome IR?

Load Grain and Strikeoff

Measure Load Cell Cal1 Cal2 E

Dump Grain Advance Striker

HOPPER\_LEVEL\_FULL  
FILL\_STATE\_HOME  
CELL\_STATE\_UNKNOWN LCELL:10367327  
DUMP\_CLOSED Empty:10367238 E=-1.4 g  
DRAWER\_STATE\_CLOSED  
REMOTE\_MODE\_OFF

Stored E: 10583980, (0 g) 10583997, (300 g) 11265304  
Norms: TW (1.0000x+0.0000) Perm (1.0000x+0.0000) Temp: 0.00  
Ambient Temp: 23.82  
Line: 15.3V  
Motor: 15.3V  
Cell: 6.5V  
5V: 5.1V  
Batt 3V: 3.1V  
Eff Perm (1.0000x+0.0000)

DDS Freq: 149000000 Hz Update

Termination  
50 Relay  
VARC Relay Gain Setting: 7  
Cell Relay

Fin 149000000 Hz Z?  
Np 100000

DFT?

DFT\_STATE\_DONE  
Z = 47.7605710572315-4.85975972564815i  
Zn = 48.007  
P = 2.101040339

LP Model  
Use Averaged  
Show Raw Z\*

Comm Check File I/O

DICKEY-john, GAC2500 CELL BOARD, 2.2, 2511006  
DICKEY-john, GAC2500 GRAIN HANDLER, 2.4  
App Version = 4.2.0.0





## MAINTENANCE

*NOTE: For customers that require a more extensive cleaning procedure with debris buildup in the cell, contact and schedule your instrument for cleaning with your dealer or authorized service center.*

**IMPORTANT: It is highly recommended the unit be regularly inspected and cleaned to ensure continued and consistent results.**

**For optimum performance, extensive cleaning should be performed weekly or more often based on surrounding environment conditions. Factors such as dust, temperature extremes, grain dust, and external humidity vary from location to location. If there are any questions about the cleanliness or instrument performance, contact your local authorized service center.**

Note: The following recommendations are provided as a guideline to maintain a robust and quality operating instrument. It should not be interpreted as an exhaustive maintenance program. Dust and debris may periodically accumulate in areas not specified in this manual. The owner is responsible for ensuring overall equipment cleanliness. If any questions arise regarding the maintenance or performance of the instrument, contact your dealer or local authorized service center.

## EXTERNAL CLEANING

The LCD display may require periodic cleaning. Use a commercial cleaner for glass lenses to remove dust.

### CAUTION

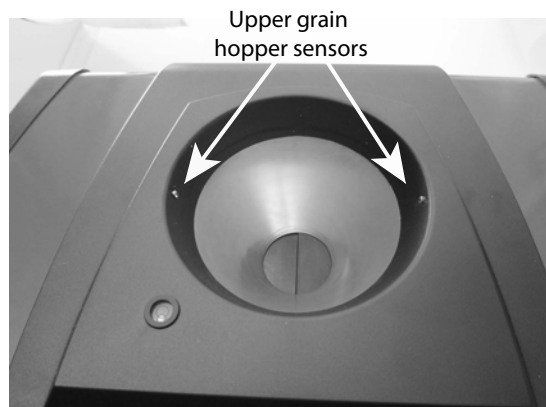
**Do not apply water, organic solvent or chemicals, such as acid and alkali to the LCD display.**

The GAC<sup>®</sup> 2500 surface can be cleaned with any cleaner designed for plastic and stainless steel surfaces.

Periodically use a rag to wipe the grain hopper and the (2) upper grain hopper sensors.

*Figure 61*

*Grain Hopper Sensors*





## INTERNAL CLEANING

Performing continuous tests can result in material accumulation around the critical internal components and adversely affect the measurement.

Two types of cleaning are recommended on an as needed basis:

- Daily clean
- Extensive clean

### DAILY CLEAN METHOD

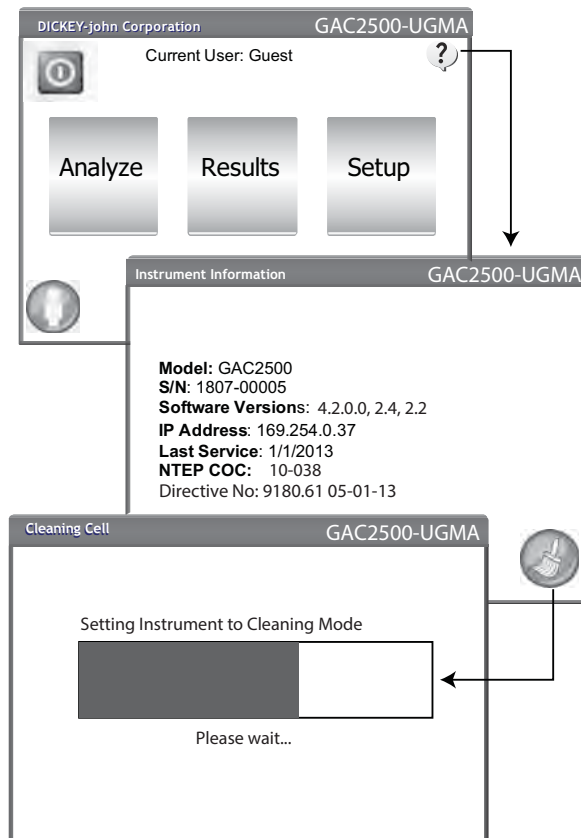
A daily clean method allows cleaning the cell and door using an automated process. During the cleaning sequence, the hopper door automatically opens. Instruments with version 2.4 grain handler firmware, the trap door opens automatically also.

#### To start the cleaning process:

1. At the Main Menu screen, press the **Instrument Information** button.
2. At the Instrument Information screen, press the **Clean** button.
  - Pressing the **Clean** button automatically begins the cleaning sequence and opens the hopper door and the trap door (version 2.4 grain handler firmware).

*Figure 62*

*Daily Clean Method*





3. Remove the grain drawer.

*Figure 63*

*Remove Grain Drawer*



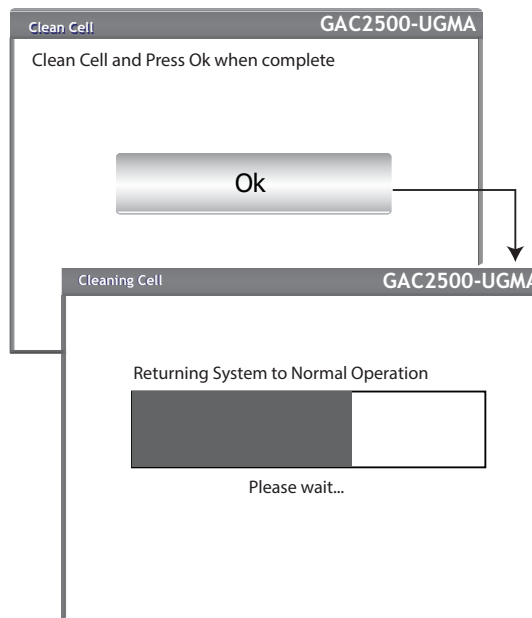
4. Using the supplied brush, manually remove any loose or stuck grain or dust from the measuring cell.
5. Press the **OK** button to return instrument to normal operation.

## CAUTION

Hands should be clear from inside the instrument before pressing the OK button.

*Figure 64*

*Cleaning Sequence*



6. Insert grain drawer.



**NOTE:** For customers that require a more extensive cleaning procedure with buildup in the cell, contact and schedule your instrument for cleaning with your dealer or authorized service center.

## EXTENSIVE CLEANING METHOD

The daily cleaning method should be performed first before proceeding to the extensive cleaning method.

### IMPORTANT:

**Extensive cleaning should be performed weekly or more often based on surrounding environment conditions. Factors such as dust, temperature extremes, grain dust, and external humidity vary from location to location. If there are any questions about the cleanliness or instrument performance, contact your local authorized service center.**

Tools required for internal mechanism cleaning:

- Brush p/n 206410003 (included with instrument)

Extensive cleaning of the instrument involves two steps to ensure optimum instrument performance:

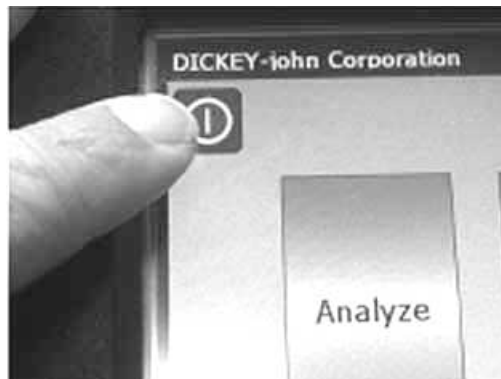
1. Internal mechanism cleaning
2. Temperature sensor probe cleaning

### To Clean the Instrument:

1. Power down the instrument.

*Figure 65*

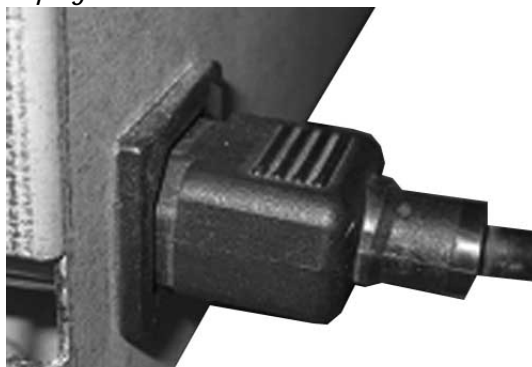
#### *Power Down*



2. Unplug power cord.

*Figure 66*

#### *Unplug Power Cord*





3. Remove other accessory cords (USB and printer).

*Figure 67*

*Remove Accessory Cords*

---



4. Remove grain drawer.

*Figure 68*

*Remove Grain Drawer*

---

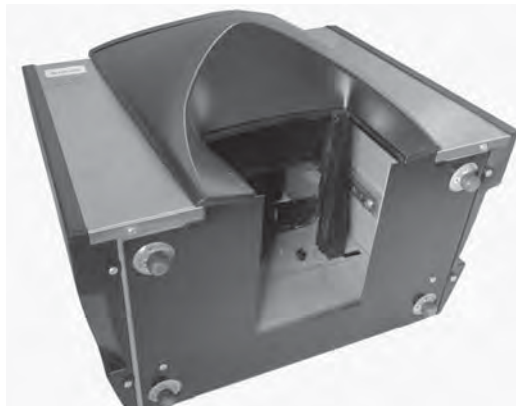


5. Place the unit on its back side.

*Figure 69*

*Place Unit on Back Side*

---

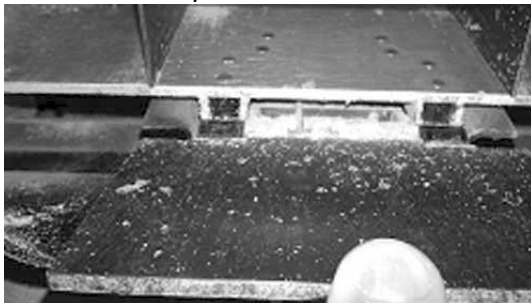




6. Manually pull down on trap door.

*Figure 70*

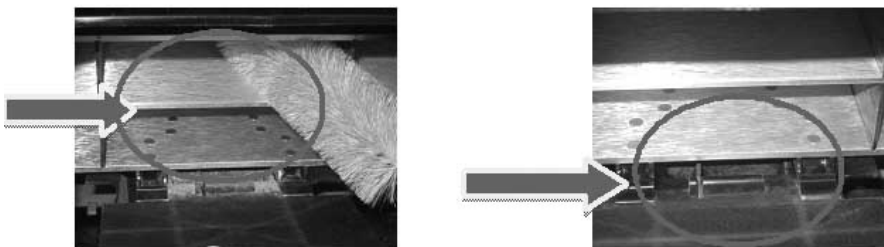
*Pull Down on Trap Door*



7. Clean surfaces around measurement cell including hinge, trap door, and edge of cell with the supplied brush.

*Figure 71*

*Clean Surface Area Around Cell, Hinge, Trap Door, Edge of Cell*



8. Close the trap door and clean hinge under trap door with brush.

*Figure 72*

*Clean Under Trap Door*



9. Proceed to instruction for cleaning the temperature sensor probe.



## CLEANING THE TEMPERATURE SENSOR PROBE

**IMPORTANT:** Any particles in front of the sensor's optics can affect measurement performance. Therefore it is crucial to sufficiently clean the sensor. For excessive dust and/or foreign material buildup on or around the temperature sensor, it is recommended the instrument be returned to DICKEY-john Service or authorized service center.

The temperature sensor may require cleaning due to dust buildup and/or foreign material that has collected around the sensor that could potentially cause temperature error readings during analysis. It is important the temperature sensor is visually inspected and cleaned each time a regular maintenance check of the instrument is conducted.

Tools required for cleaning the temperature sensor probe:

- 6" long, tapered tip cotton swab (i.e. McMaster-Carr p/n 71035T54)

*Figure 73*

*Recommended Cotton Swab*



- 99% Isopropyl Alcohol

*Figure 74*

*99% Isopropyl Alcohol*



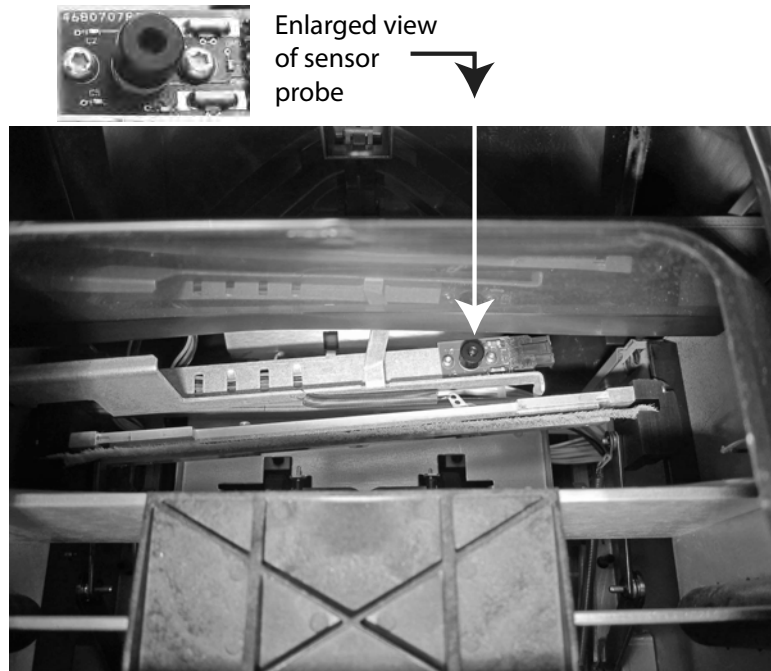


## TEMPERATURE SENSOR LOCATION

With the instrument placed on its backside and looking inside the instrument, the sensor probe is located in the middle of the instrument toward the top and front attached to a circuit board.

*Figure 75*

*Sensor Probe Location*



## To Clean the IR Temperature Sensor:

1. Gently place instrument upside down.

*Figure 76*

*Place Instrument Upside Down*





2. Wet one end of the cotton swab (recommended McMaster-Carr p/n 71035T5) with 99% Isopropyl alcohol.

*Figure 77*

*Wet Swab with Alcohol*



**IMPORTANT: Any particles in front of the sensor's optics can affect measurement performance. Therefore it is crucial to sufficiently clean the sensor.**

3. The sensor is located inside the black tube. Insert the swab inside the black tube and gently clean the IR temperature sensor with the wet end of the cotton swab.

*Figure 78*

*Inserting the Cotton Swab*





*Figure 79*

*Cleaning the Sensor with Cotton Swab*



4. Allow the temperature sensor to dry for 90 seconds then gently clean with the dry end of the cotton swab.
5. Visually inspect the temperature sensor as well as all other areas cleaned to ensure the instrument is free from debris. If there is any question about the cleanliness of the instrument, it should be returned to a dealer or authorized service center.
6. If cleaning is acceptable, return instrument to upright position and replace the drawer.
7. Reconnect power cable and accessory cords.
8. Power on instrument.

**IMPORTANT:** The foregoing recommendations are provided as a guideline to maintain a robust and quality operating GAC 2500. It should not be interpreted as an exhaustive maintenance program. Dust and debris may periodically accumulate in areas not specified in this manual. The owner is responsible for ensuring overall equipment cleanliness. If any questions arise regarding the maintenance or performance of the instrument, contact your dealer or local authorized service center.



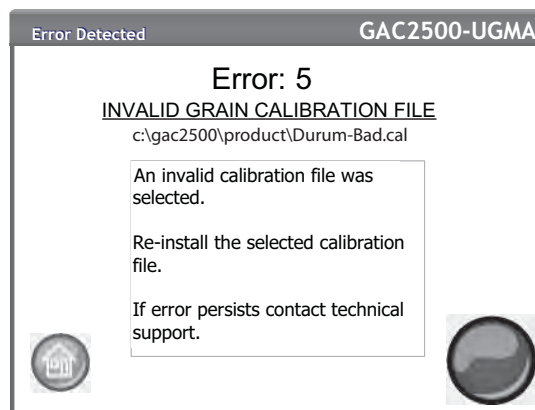
## TROUBLESHOOTING

If the system locks, press and hold the **On/Off** button on the front of machine until system turns off or unplug instrument power. Wait a few seconds and then power on.

The GAC<sup>®</sup> 2500 contains a microprocessor to control grain sample measurements and self-checks that determine the integrity of the internal electronics. If any limit is exceeded or malfunctions occur an error code displays with a recommended resolution.

*Figure 80*

*Error Screen Example*





## ERROR MESSAGES

Error messages display when an abnormal event occurs. An error can be acknowledged by pressing the **Initiate** button. For any failure that persists, contact DICKEY-john Technical Support at 1-800-637-3302.

# OPERATOR'S MANUAL



ERROR CODE	ERROR	PROBABLE CAUSE	CORRECTIVE ACTION
1	Empty Cell Measurement Out of Spec	Moisture or dirt buildup in cell.	Dump grain and verify cell is clean and free of grain in and surrounding the cell.
2	Empty Cell Weight Out of Spec	Empty cell measurement is out of tolerance	Dump grain and verify cell is clean and free of grain in and surrounding the cell.
3	No Products Installed	No product calibrations were found on the machine.	Install product calibration files.
4	Fill Motor Jammed	The motor has stalled while loading grain from a possible obstruction.	Clear blockage from cell.
5	Invalid Grain Calibration File	An invalid calibration file was selected.	Re-install the selected calibration file.
6	Moisture Too High	Measured product is above the moisture upper limit of the calibration.	Verify sample filled the cell.
7	Moisture Too Low	Measured product is below the moisture lower limit of the calibration.	Verify sample filled the cell.
8	Instrument Low Temp Limit Exceeded	Instrument temperature is less than the allowed limit of 0 degrees C.	Move unit to a warmer environment or allow to warm up.
9	Grain High Temp Limit Exceeded	Grain temperature has exceeded the unit specification to analyze grain.	Allow grain to cool and then re-analyze.
10	Grain Low Temp Limit Exceeded	Grain temperature has exceeded the unit specification to analyze grain.	Allow grain to warm and then re-analyze.
11	Sample Weight Too High	Test weight is greater than the range specified for the calibration selected.	Use a more representative sample and re-analyze grain. Verify correct grain calibration is selected.
12	Sample Weight Too Low	Test weight is lower than the range specified for the calibration selected.	Use a more representative sample and re-analyze grain. Verify correct grain calibration is selected.
13	No Communication	An internal communication failure has occurred and communication has been lost.	Power unit off and turn back on to reset.
14	Instrument High Temp Limit Exceeded	Instrument temperature is higher than the allowed limit of 45 degrees C.	Check unit ventilation or move to a cooler environment.
15	Unit to Grain Differential	The difference between grain temperature and machine temperature has exceeded the unit specification to analyze grain.	Allow grain and machine temperature to equalize and then re-analyze.
16	Internal Power Supply Out of Spec	Unit internal voltage is out of specification.	Service is required. Contact DICKEY-john Tech Support at 1-800-637-3302.
17	Unable to Predict Moisture	A corrupt instrument calibration file or other unexpected error.	Dump sample and re-analyze.
19	Instrument Needs Updated	Firmware in the instrument is out of date for this application.	Update device with new firmware.
21	File I/O Error	An unexpected file i/o error has occurred.	An obstruction has occurred in the cell. Blockage must be cleared before testing can resume.
50	Weight Measurement Device Error	An error has occurred with the load cell.	Power unit off and turn back on to reset. Service unit if failure continues.
51	Invalid Password	A service function with an invalid password was attempted.	If service is required, contact DICKEY-john Technical Support at 1-800-637-3302 for assistance on how to obtain the password and proper service procedure.
52	Date/Time Incorrect	The programmed machine date is less than expected.	Program the instrument date and time. If problem persists, then the battery backup for the internal clock may need to be replaced. Contact DICKEY-john Technical Support at 1-800-637-3302 for service.
53	Cold Sample Moisture Too High	The sample is too high in moisture to accurately read at its current temperature.	Warm the sample above the low temperature threshold specified in the product calibration file and rerun the measurement.
55	Dump Motor Timeout	The dump mechanism does not appear to be closing.	Check that the dump motor optical sensor is clean and there is no interference in the dump mechanism. Press the Green button to retry. If error persists, contact technical support at 1-800-637-3302.
100	Unexpected Application Crash	The application has encountered an unexpected error.	Press the Initiate (green) button or cycle power to reboot the instrument. If problem persists, contact Dickey-john Tech Support at 1-800-637-3302.



*Dealers have the responsibility of calling to the attention of their customers the following warranty prior to acceptance of an order from their customer for any DICKEY-john product.*

## **DICKEY-john® WARRANTY**

DICKEY-john warrants to the original purchaser for use that, if any part of the product proves to be defective in material or workmanship within one year from date of original installation, and is returned to DICKEY-john within 30 days after such defect is discovered, DICKEY-john will (at our option) either replace or repair said part. This warranty does not apply to damage resulting from misuse, neglect, accident, or improper installation or maintenance; any expenses or liability for repairs made by outside parties without DICKEY-john's written consent; damage to any associated equipment; or lost profits or special damages. Said part will not be considered defective if it substantially fulfills the performance expectations. THE FOREGOING WARRANTY IS EXCLUSIVE AND IN LIEU OF ALL OTHER WARRANTIES OF MERCHANTABILITY, FITNESS FOR PURPOSE, AND OF ANY OTHER TYPE, WHETHER EXPRESS OR IMPLIED. DICKEY-john neither assumes nor authorizes anyone to assume for it any other obligation or liability in connection with said part and will not be liable for consequential damages. Purchaser accepts these terms and warranty limitations unless the product is returned within fifteen days for full refund of purchase price.

**For DICKEY-john Service Department, call  
1-800-637-3302 in either the U.S.A. or Canada**



**Headquarters:**

5200 Dickey-john Road, Auburn, IL USA 62615

TEL: 217 438 3371, FAX: 217 438 6012, WEB: [www.dickey-john.com](http://www.dickey-john.com)

**Europe:**

DICKEY-john Europe S.A.S, 165, boulevard de Valmy, 92706 – Colombes – France

TEL: 33 (0) 1 41 19 21 80, FAX: 33 (0) 1 47 86 00 07 WEB: [www.dickey-john.eu](http://www.dickey-john.eu)